

Technical Data Sheet ECOTROL® Control Valve

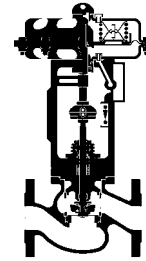

TD_8C

General Data

Series	8C
Nominal size DN / NPS	15 - 100 / ½" – 4"
Nominal pressure PN / ANSI	16 - 63 / Class 150 - 600
Face-to-Face dimension	PN16/40: EN558 Series 1; PN 63: EN558 Series 2; ANSI Class 150 – 600: ISA 75.08.01
Characteristic	equal percentage or linear
Rangeability	50:1
Plug guide	stem guided option: integrated double guiding (retrofitable) for DN40 - DN100 (1½" - 4") ¹⁾
Seat leakage	metal sealing: IEC 60534-4 leakage class IV (0.01% Kvs value); option: leakage class V as well as soft sealing: IEC 60534-4 leakage class VI
Bellows seal (optional)	seamless, double walled, made of 1.4571; option: Hastelloy® and other materials
Heating jacket (optional)	connections: flanges DN 15 PN 40 (1/2" ANSI 150/300)
Low-temperature version (optional)	down to -196°C, with cover flange if required

Materials

	EN	for temperatures	ASTM	for temperatures
Body material	1.0619 GP240GH	-10 to 400°C	A 216 WCB	-29°C to 425°C
	1.4408 G-X 5 CrNiMo 19 11 2	-10 to 400°C	A 351 CF8M	-29°C to 400°C
	1.4408 G-X 5 CrNiMo 19 11 2	-196 to 400°C	A 351 CF8M	-196°C to 400°C
	1.6220 G20Mn5	-50 to 345°C	A 352 LCC	-46°C to 345°C
	1.7357 G17CrMo5-5	-10 to 530°C	A 217 WC6	-29°C to 530°C
Bonnet material	≤ DN 65 (2") 1.4408 but for body material 1.7357: 1.7335	-10 to 400°C -10 to 530°C	A 351 CF8M A182F12Cl.3	-29°C to 400°C -29°C to 530°C
	≥ DN 80 (3") same material as body, but for body materials 1.0619/A216WCB, 1.6220 /A352LCC and 1.7357/A217WC6 c/w stuffing box sleeve made of 1.4571 (AISI 316TI)			

Valve trim materials

Material no.	Parabolic plug P1	Double-guided parabolic plug P1 ¹⁾	Perforated plug L1	Seat	Seat seal	Max. medium temperature
1	1.4571	1.4571	-	1.4571	metal	same as stem seal
2	-	-	1.4571	1.4571 nitrided	metal	same as stem seal
3	1.4112 hardened	1.4112 hardened	1.4112 hardened	1.4112 hardened	metal	same as stem seal
4	1.4571	-	-	1.4571	PTFE/FKM	-20 ~ 180°C
5	1.4571	-	-	1.4571	PTFE/EPDM	-29 ~ 140°C
6	1.4571	-	-	1.4571	PTFE	-196 ~ 180°C

1) only as of nominal size ≥ DN40 (1 1/2") with KV_s ≥ 25 (C_{vs} ≥ 29)

Technical Data Sheet ECOTROL® Control Valve

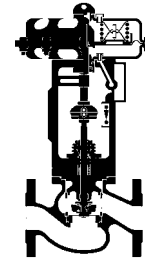

TD_8C

Stem sealing

Seal type	Seal (pos. A)	Profile ring (pos. B)	O-ring (pos. C)	Wiper ring (pos. D)	Allowed medium temperature (pressure)	Bonnet flange (DEK)	Comments
maintenance-free double seal	PTFE V-ring	EPDM	EPDM	NBR	-29 ~ 180°C (≤ PN 63)	1: standard	preloaded with stainless steel spring
maintenance-free double seal	PTFE V-ring	FKM	FKM	NBR	-20 ~ 200°C (≤ PN 63)	1: standard	preloaded with stainless steel spring
adjustable	PTFE braided	-	-	NBR	-196 ~ 250°C	1: standard 3: cooling fins	manual adjustable
adjustable	reinforced graphite/Inconel	-	-	NBR	-29 ~ 400°C	1: standard 3: cooling fins	manual adjustable
adjustable	pure graphite	-	-	NBR	-29 ~ 530°C	1: standard 3: cooling fins	manual adjustable
maintenance free double seal	PTFE V-ring	EPDM	EPDM	NBR	-196 ~ 200°C (≤ PN 63)	5: insulating column	low temperature
bellow sealing made of 1.4571 or Hastelloy C	PTFE V-ring	EPDM (FKM)	EPDM (FKM)	NBR	-100~200°C	4: bellows	preloaded with stainless steel spring

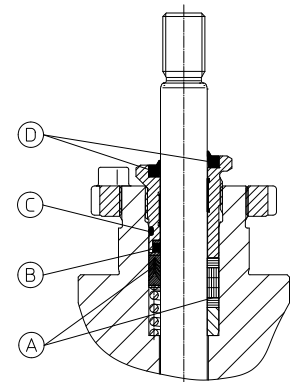

Weight and dimensions

ECOTROL® globe valve with multi-spring actuator type 812 ARCAPAQ®

Dimensions (in mm) of valves with flanges acc. to DIN EN 1092-1 resp. ANSI Class 150/300/600 RF/RTJ

		DN ANSI NPS	15 1/2"	20 -	25 1"	32 -	40 1 1/2"	50 2"	65 -	80 3"	100 4"
Valve Type 8C	VBL PN16-PN40		130	150	160	180	200	230	290	310	350
	VBL PN63		210	230	230	260	260	300	340	380	430
	VBL Class 150 RF		184	-	184	-	222	254	-	298	352
	VBL Class 150 RTJ		-	-	197	-	235	267	-	311	365
	VBL Class 300 RF		190	-	197	-	235	267	-	317	368
	VBL Class 300 RTJ		201	-	210	-	248	283	-	333	384
	VBL Class 600 RF		203	-	210	-	251	286	-	337	394
	VBL Class 600 RTJ		201	-	210	-	251	289	-	340	397
VH	DEK1/7		115				DEK1=115 / DEK7=135			156	181
	DEK3/8		170						263	267	
	DEK4		228				233			390	390
	DEK5		on request								
VU			44	51	56	65	74	75	90	101	136
Actuator Type 812	ØA	MFI	270								
		MFIII							400		
	AH	MFI	361						404		
		MFI(v)					381				
		MFIII					489				
	AHV	MFI	508						551		
		MFI(v)					528				
		MFIII					651				
	Weight * approx. kg	MFI	21	22.5	25	27	33	35	37	75	100
		MFIII							101		126
B			150						200		

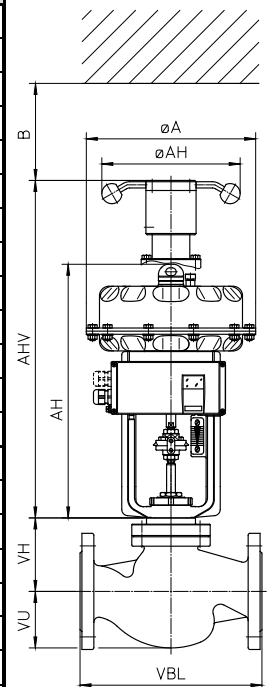

* Weight: valve (with DEK1) + actuator without handwheel

Technical Data Sheet ECOTROL® Control Valve

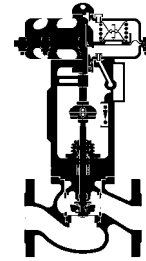

TD_8C

Weight and dimensions

ECOTROL® globe valve with multi-spring actuator type 812 ARCAPAQ®

Dimensions (in mm) of valves with butt-weld ends (SE) and butt-weld ends with spool pieces (VE)

DN ANSI NPS		15 1/2"	20 -	25 1"	32 -	40 1 1/2"	50 2"	65 -	80 3"	100 4"	
Valve Type 8C	VBL PN16-PN63 SE	250	-	250	250	300	300	340	380	430	
	VBL PN16-PN63 VE	350	350	350	350	400	400	500	500	600	
	VBL Class 150/300/600 SE	250	-	250	-	300	292	330	356	432	
	VBL Class 150/300/600 VE	350	350	350	350	400	400	500	500	600	
	VH	DEK1/7	115						156	181	
		DEK3/8	170						263	267	
		DEK4	228			233			390	390	
DEK5		on request									
VU		44	51	56	65	74	75	90	101	136	
Actuator Type 812	ØA	MFI	270								
		MFIII								400	
	AH	MFI	361						404		
		MFI(v)	-			381				-	
		MFIII	-			489					
	AHV	MFIII(v)	-							551	
		MFI	508						551		
		MFI(v)	-			528				-	
		MFIII	-			651					
	Weight * approx. kg	MFI	21	22.5	25	27	33	35	37	75	100
		MFIII								101	126
B		150							200		

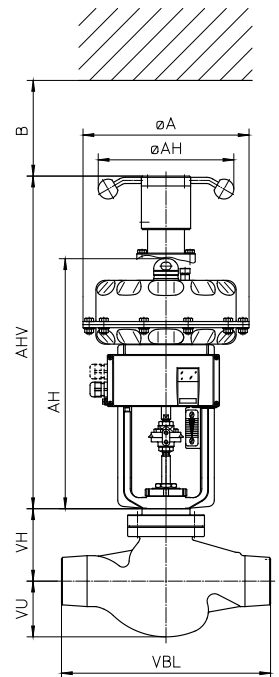

* Weight: valve (with DEK1) + actuator without handwheel

Butt-weld ends acc. to DIN EN 12627

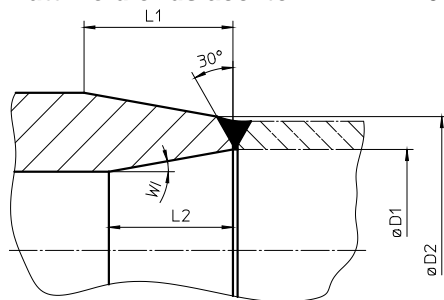

DN	PN	Pipe AD	ØD1	ØD2	L1	WA	L2	WI
15	40	21,3	17,3	22	48	0°	>33,6	1,9°
	63	21,3	17,3	22	48	0°	>33,6	1,9°
25	40	33,7	28,5	35	48	0°	>33,6	2,9°
	63	33,7	28,5	35	48	0°	>33,6	2,9°
40	40	48,3	43,1	50	50	0°	>33,6	2,5°
	63	48,3	42,5	50	50	0°	>33,6	2°
50	40	60,3	54,5	61,5	50	5°	>33,6	3,5°
	63	60,3	53,9	61,5	50	5°	>33,6	3°
80	40	88,9	82,5	91	49	8°	>33,6	2°
	63	88,9	80,9	91	49	8°	>33,6	0,7°
100	40	114,3	107,1	116	48	5°	>33,6	5°
	63	114,3	105,3	116	48	5°	>33,6	4°

Butt-weld ends acc. to ASME B16.25

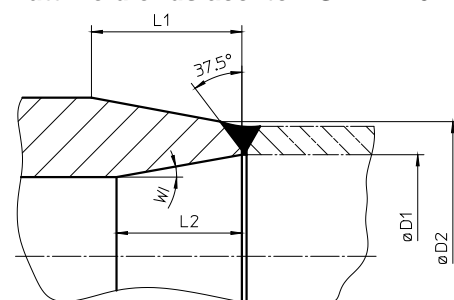

NPS	Class	Pipe AD	D1	D2	L1	WA	L2	WI
1/2	300	21,3	15,76	22	48	0°	>33,6	0,6°
	600	21,3	13,84	22	48	0°	>33,6	0°
1	300	33,7	26,94	35	48	0°	>33,6	1,5°
	600	33,7	24,6	35	48	0°	>33,6	0°
1 1/2	300	48,3	40,94	50	50	0°	>33,6	0,7°
	600	48,3	38,14	50	50	0°	>33,6	0°
2	300	60,3	52,48	61,5	48	5°	>33,6	2°
	600	60,3	49,22	61,5	48	5°	>33,6	0°
3	300	88,9	77,92	91	48	8°	>33,6	3°
	600	88,9	73,66	91	48	8°	>33,6	0°
4	300	114,3	102,26	116	51,8	5°	>33,6	1,8°
	600	114,3	97,18	116	51,8	5°	>33,6	0°

Technical Data Sheet ECOTROL® Control Valve

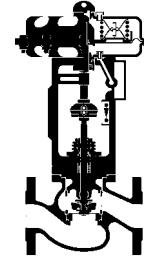

TD_8C

Max. shut off differential pressure in bar

ECOTROL® 8C PN16 - PN63 as well as ANSI Class 150 - 600 Valid for valves w/o pressure balancing c/w PTFE-packing and for leakage class IV Flow to open (FTO) (at p ₂ = 0 bar g)																			
Actuator series 812										Air to open/ Spring to close No. of springs				Air to close/ Spring to open No. of springs					
										3	6	9	12	3	3	3	6	6	
DN	Stroke (mm)	Actuator size	P1		L1 lin		L1 =%		Seat-Ø (mm)	Min. air supply (bar)									
			Kv	Cv	Kv	Cv	Kv	Cv		bar	bar	bar	bar	3,0	4,5	6,0	4,5	6,0	
15 1/2"	20	MFI-20 (320 cm ²) 812-213..	4,0	4,6	2,5	2,9	2,5	2,9	16	80,9	100	-	-	100	100	100	100	100	
			1,6	1,9	-	-	-	-	10	100	100	-	-	100	100	-	100	100	
			0,63	0,73	-	-	-	-	5	100	-	-	-	-	100	-	-	100	100
20	20	MFI-20 (320 cm ²) 812-213..	4,0	4,6	2,5	2,9	2,5	2,9	16	80,9	100	-	-	100	100	100	100	100	
			1,6	1,9	-	-	-	-	10	100	100	-	-	100	100	-	100	100	
			0,63	0,73	-	-	-	-	5	100	-	-	-	-	100	-	-	100	100
25 1"	20	MFI-20 (320 cm ²) 812-213..	10	11,6	8,0	9,3	7,5	8,7	25	30,2	76,6	-	-	76,6	100	100	76,6	100	
			4,0	4,6	2,5	2,9	2,5	2,9	16	80,9	100	-	-	100	100	100	100	100	
			1,6	1,9	-	-	-	-	10	100	100	-	-	100	100	-	100	100	
32	20	MFI-20 (320 cm ²) 812-213..	10	11,6	8,0	9,3	7,5	8,7	25	30,2	76,6	-	-	76,6	100	100	76,6	100	
			4,0	4,6	2,5	2,9	2,5	2,9	16	80,9	100	-	-	100	100	100	100	100	
			1,6	1,9	-	-	-	-	10	100	100	-	-	100	100	-	100	100	
40 1 1/2"	20	MFI-20 (320 cm ²) 812-223..	25	29	25	29	18	21	37	12,0	33,2	-	-	33,2	75,6	100	33,2	75,6	
			16	19	12	14	10	11,6	30	19,8	52,1	-	-	52,1	100	100	52,1	100	
			10	11,6	8,0	9,3	7,5	8,7	25	30,2	76,6	-	-	76,6	100	100	76,6	100	
40 1 1/2"	20	MFI-20(v) (320 cm ²) 812-224..	25	29	25	29	18	21	37	19,0	47,3	-	-	33,2	75,6	100	33,2	75,6	
			16	19	12	14	10	11,6	30	30,6	73,6	-	-	52,1	100	100	52,1	100	
			10	11,6	8,0	9,3	7,5	8,7	25	45,7	100	-	-	76,6	100	100	76,6	100	
40 1 1/2"	20	MFIII-30 (720 cm ²) 812-334..	25	29	25	29	18	21	37	54,4	100	100	-	86,2	100	100	86,2	100	
			16	19	12	14	10	11,6	30	84,3	100	-	-	100	100	-	100	100	
			10	11,6	8,0	9,3	7,5	8,7	25	100	-	-	-	100	-	-	100	100	
50 2" 65	20	MFI-20 (320 cm ²) 812-223..	40	46	35	41	20	23	48	6,1	18,7	-	-	18,7	43,9	69,1	18,7	43,9	
			25	29	25	29	18	21	37	12,0	33,2	-	-	33,2	75,6	100	33,2	75,6	
			16	19	12	14	10	11,6	30	19,8	52,1	-	-	52,1	100	100	52,1	100	
			10	11,6	8,0	9,3	7,5	8,7	25	30,2	76,6	-	-	76,6	100	100	76,6	100	
		MFI-20(v) (320 cm ²) 812-224..	40	46	35	41	20	23	48	10,3	27,1	-	-	18,7	43,9	69,1	18,7	43,9	
			25	29	25	29	18	21	37	19,0	47,3	-	-	33,2	75,6	100	33,2	75,6	
			16	19	12	14	10	11,6	30	30,6	73,6	-	-	52,1	100	100	52,1	100	
			10	11,6	8,0	9,3	7,5	8,7	25	45,7	100	-	-	76,6	100	100	76,6	100	
		MFIII-30 (720 cm ²) 812-334..	40	46	35	41	20	23	48	30,2	69,1	85,8	100	50,2	100	100	50,2	100	
			25	29	25	29	18	21	37	52,5	100	100	-	86,2	100	100	86,2	100	
			16	19	12	14	10	11,6	30	81,4	100	-	-	100	100	-	100	100	
			10	11,6	8,0	9,3	7,5	8,7	25	100	-	-	-	100	-	-	100	100	

Please pay attention to the pressure / temperature rating of the valve body!

For other valve/packing versions, refer to ARCA-VENA valve sizing.



Technical Data Sheet ECOTROL® Control Valve

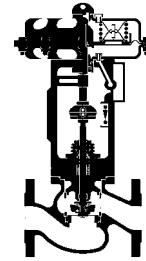

TD_8C

ECOTROL® 8C PN16 - PN63 as well as ANSI Class 150 - 600

Valid for valves **w/o pressure balancing** c/w PTFE-packing and for leakage class IV

Flow to open (FTO) (at p₂ = 0 bar g)

Actuator series 812										Air to open/ Spring to close No. of springs				Air to close/ Spring to open No. of springs						
										3	6	9	12	3	3	3	6	6		
DN	Stroke (mm)	Actuator size	P1		L1 lin		L1 =%		Seat-Ø (mm)	Min. air supply (bar)										
			Kv	Cv	Kv	Cv	Kv	Cv		bar	bar	bar	bar	3,0	4,5	6,0	4,5	6,0		
80 3"	30	MFI-30 (320 cm ²) 812-234..	100	116	80	93	70	83	80	-	5,5	-	-	5,5	14,5	23,6	5,5	14,5		
			63	73	63	73	55	64	62	2,6	10,1	-	-	10,1	25,2	40,3	10,1	25,2		
			40	46	40	46	20	23	48	5,6	18,2	-	-	18,2	43,4	68,6	18,2	43,4		
		MFIII-30 (720 cm ²) 812-334..	100	116	80	93	70	83	80	5,9	15,5	21,0	26,6	16,8	37,2	57,6	16,8	37,2		
			63	73	63	73	55	64	62	10,9	26,7	35,9	45,3	29,0	63,0	97,0	29,0	63,0		
			40	46	40	46	20	23	48	19,4	45,9	61,2	76,9	49,7	100	100	49,7	100		
		MFIII-30(v) (720 cm ²) 812-336..	100	116	80	93	70	83	80	11,4	26,3	33,1	40,0	16,8	37,2	57,6	16,8	37,2		
			63	73	63	73	55	64	62	16,2	37,3	56,2	67,5	29,0	63,0	97,0	29,0	63,0		
			40	46	40	46	20	23	48	28,2	63,5	95,0	100	49,7	100	100	49,7	100		
100 4"	30	MFI-30 (320 cm ²) 812-234..	160	186	120	140	80	93	100	-	3,1	-	-	3,1	8,9	14,7	3,1	8,9		
			100	116	80	93	70	83	80	-	5,5	-	-	5,5	14,5	23,6	5,5	14,5		
			63	73	63	73	55	64	62	2,6	10,1	-	-	10,1	25,2	40,3	10,1	25,2		
		MFIII-30 (720 cm ²) 812-334..	160	186	120	140	80	93	100	3,4	9,5	13,0	16,6	10,3	23,4	36,5	10,3	23,4		
			100	116	80	93	70	83	80	5,9	15,5	21,0	26,6	16,8	37,2	57,6	16,8	37,2		
			63	73	63	73	55	64	62	10,9	26,7	35,9	45,3	29,0	63,0	97,0	29,0	63,0		
		MFIII-30(v) (720 cm ²) 812-336..	160	186	120	140	80	93	100	19,4	45,9	61,2	76,9	49,7	100	100	49,7	100		
			100	116	80	93	70	83	80	6,8	16,4	20,8	25,1	10,3	23,4	36,5	10,3	23,4		
			63	73	63	73	55	64	62	11,4	26,3	33,1	40,0	16,8	37,2	57,6	16,8	37,2		
					100	116	80	93	70	83	80	19,9	44,9	56,2	67,5	29,0	63,0	97,0	29,0	63,0
					63	73	63	73	55	64	62	34,5	76,1	95,0	100	49,7	100	100	49,7	100
					40	46	40	46	20	23	48									

ECOTROL® 8C PN16 - PN63 as well as ANSI Class 150 - 600

Valid for valves **with pressure balancing** EPDM or FKM c/w PTFE-packing and for leakage class IV

Flow to open (FTO) (at p₂ = 0 bar g)

Actuator series 812										Air to open/ Spring to close No. of springs				Air to close/ Spring to open No. of springs					
										3	6	9	12	3	3	3	6	6	
DN	Stroke (mm)	Actuator size	P1		L1 lin		L1 =%		Seat-Ø (mm)	Min. air supply (bar)									
			Kv	Cv	Kv	Cv	Kv	Cv		bar	bar	bar	bar	3,0	4,5	6,0	4,5	6,0	
80 3"	30	MFI-30 (320 cm ²) 812-234..	100	116	80	93	70	83	80	-	65,9	-	-	65,9	100	100	65,9	100	
			63	73	63	73	55	64	80	-	65,9	-	-	65,9	100	100	65,9	100	
			40	46	40	46	20	23	80	-	65,9	-	-	65,9	100	100	65,9	100	
		MFIII-30 (720 cm ²) 812-334..	100	116	80	93	70	83	80	73,1	100	100	100	100	100	100	100	100	
			63	73	63	73	55	64	80	73,1	100	100	100	100	100	100	100	100	
			40	46	40	46	20	23	80	73,1	100	100	100	100	100	100	100	100	
100 4"	30	MFI-30 (320 cm ²) 812-234..	160	186	120	140	80	93	100	-	49,7	-	-	49,7	100	100	49,7	100	
			100	116	80	93	70	83	100	-	49,7	-	-	49,7	100	100	49,7	100	
			63	73	63	73	55	64	100	-	49,7	-	-	49,7	100	100	49,7	100	
		MFIII-30 (720 cm ²) 812-334..	160	186	120	140	80	93	100	56,9	100	100	100	100	100	100	100	100	
			100	116	80	93	70	83	100	56,9	100	100	100	100	100	100	100	100	
			63	73	63	73	55	64	100	56,9	100	100	100	100	100	100	100	100	

Technical Data Sheet ECOTROL® Control Valve

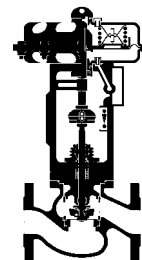

TD_8C

ECOTROL® 8C model code

0. Operating conditions		7. Body material (cont.)		15. Seat wear / tear protection (cont.)	
Medium:		4	1.7357	5	Colsterised
Temp.:	°C	5	1.6620	9	Acc. to spec.
Press. P ₁ :	bar abs.	6	A216WCB	16. Seat/ Plug seal ¹⁾	
Press. P ₂ :	bar abs.	7	A351CF8M	0	Leakage Class IV (metal to metal)
P Design	bar g	8	A217WC6	1	Leakage Class V (metal to metal)
T Design	°C	9	Acc. to spec.	2	Leakage Class VI soft sealing PTFE/EPDM
1. Series		8. Guide ¹⁾		3	Leakage Class VI soft sealing PTFE/FKM
8C	Single Seat Globe Control Valve ECOTROL® 8C	0	Stem guided (Standard)	4	Leakage Class VI soft sealing PTFE/Trapezium
2. Top flange		1	Double guided	9	Acc. to spec.
1	Standard	9	Acc. to spec.	17. Cage retainer ¹⁾	
3	Cooling fins	9. KVs Value		0	Standard
4	Bellows sealing	xxx	Acc. to spec.	1	LN (low noise) not controlled
5	Extended bonnet (insulating column)	KVs values acc. to table		2	LN (low noise) controlled
7	Standard c/w balancing (DN≥80)	10. Performance curve characteristic		9	Acc. to spec.
8	Cooling fins c/w balancing (DN≥80)	g	=%	18. Seat retainer ¹⁾	
9	Special design acc. to spec.	l	linear	0	Without
3. Plug design		m	modified	1	LK1
P1, P3	Parabolic plug (1-step resp. 3-steps)	11. Plug materials ¹⁾		2	LK2
L1-L2-L3	Perforated plug (1-2-3 steps)	1	1.4571	5	SLK1
4. Nominal diameter (DN) – DIN/ ANSI		3	1.4112	6	SLK2
15	DN 15 / ANSI ½"	9	Acc. to spec.	19. Stem seal ¹⁾	
20	DN 20 (only with DIN flanges and FTF)	12. Plug wear / tear protection ¹⁾		1	PTFE/V-Ring/EPDM square ring
25	DN 25 / ANSI 1"	0	Standard (w/o)	2	PTFE/V-Ring/ITON square ring
32	DN 32 (only with DIN flanges and FTF)	1	Nitrided	3	Latty 6118/ETF Inconel
40	DN 40 / ANSI 1½"	2	Hardened	4	Graphite 0901
50	DN 50 / ANSI 2"	3	Sealing surface stellited	5	Graphite/PTFE 6226/6232
65	DN 65 (only with DIN flanges and FTF)	4	Completely stellited	9	Special design acc. to spec.
80	DN 80 / ANSI 3"	5	Colsterised	20. Special designs	
100	DN 100 / ANSI 4"	9	Others (acc. to spec.)	0	Standard
5. Pressure rating (PN)		13. Pressure Balancing ¹⁾		1	AD2000
16	PN 16	0	Standard (w/o)	2	NACE
40	PN 40	1	Piston rings	3	Oxygen version
63	PN 63	2	EPDM-Quadrang	9	Others (acc. to spec.)
150	Class 150	3	FKM-Quadrang	21. Material inspections (pressure retaining parts)	
300	Class 300	5	PTFE spring loaded	0	w/o
600	Class 600	9	Others (acc. to spec.)	1	EN 10204-2.1
6. Connections		14. Seat materials ¹⁾		2	EN 10204-3.1
0	Flanges with raised face (standard)	1	1.4571	3	EN 10204-3.2
1	Flanges c/w groove	3	1.4112	9	Others (on request)
2	Flanges c/w tongue	9	Others (acc. to spec.)	22. Final inspections	
3	Flanges c/w projection/recess	15. Seat wear/tear protection ¹⁾		0	None
4	Butt-weld ends	0	Standard (w/o)	1	EN 10204-2.1
5	Butt-weld ends c/w spool pieces	1	Nitrided	2	EN 10204-2.2
7	RTJ	2	Hardened	3	EN 10204-3.1
9	Others (acc. to spec.)	3	Sealing surface stellited	4	EN 10204-3.2
7. Body materials ¹⁾		4	Completely stellited	9	Others (on request)
2	1.0619				
3	1.4408				

¹⁾ In accordance with customer specifications, or selected by the manufacturer in accordance with customer specifications (medium, pressure, temperature, etc.).

Blue letters: Standard design, at most 3 pieces, available within one week.

Example:

8C - 1 - P1 - 15 - 40 - 0 - 2	Position 1-7 / basic data
Series 8C - with standard bonnet – one-step parabolic plug - DN15 – PN40 – flange EN1092 B1 – body 1.0619	
0 - 4,0 - g - 1 - 0 - 0 - 1 - 0 - 0 - 0 - 0 - 1	Position 8-19 / valve trims
Single stem guide – KVs 4.0 – equal percentage – plug made of 1.4571 – no wear/tear protection – not balanced – seat made of 1.4571 – no wear/tear protection – leakage class IV – standard cage retainer – no seat retainer – stem seal PTFE V-ring / EPDM quad ring	
0 - 1 - 1	Position 20-22 / version/inspections
Standard version – material inspection EN 10204 3.1 – final specification EN 10204 3.1	

