

**JC
VALVES**

The quality option

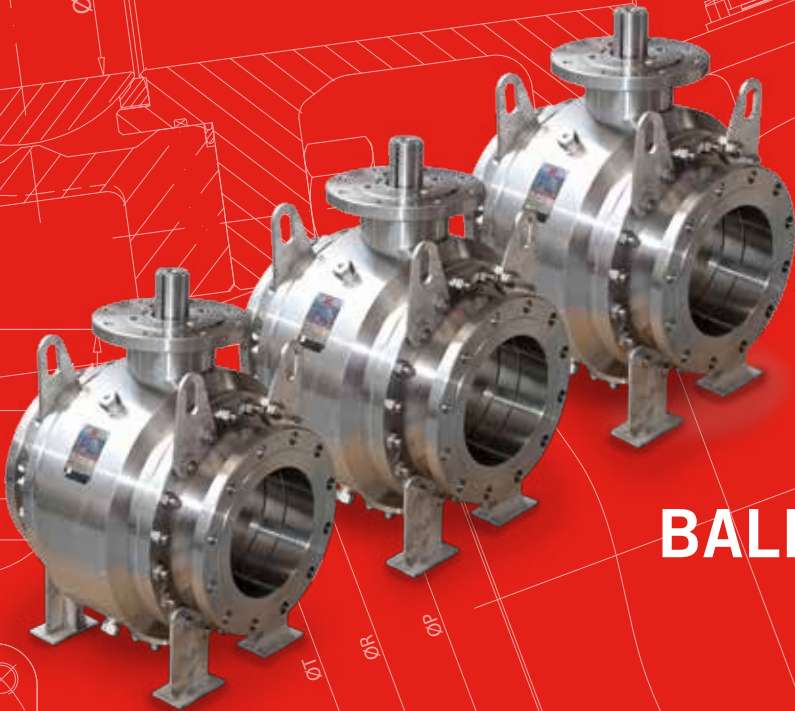

BALL VALVES

DN-300 (12) to DN-400 (16)
Class-150 & 300
DN-150 (6) to DN-300

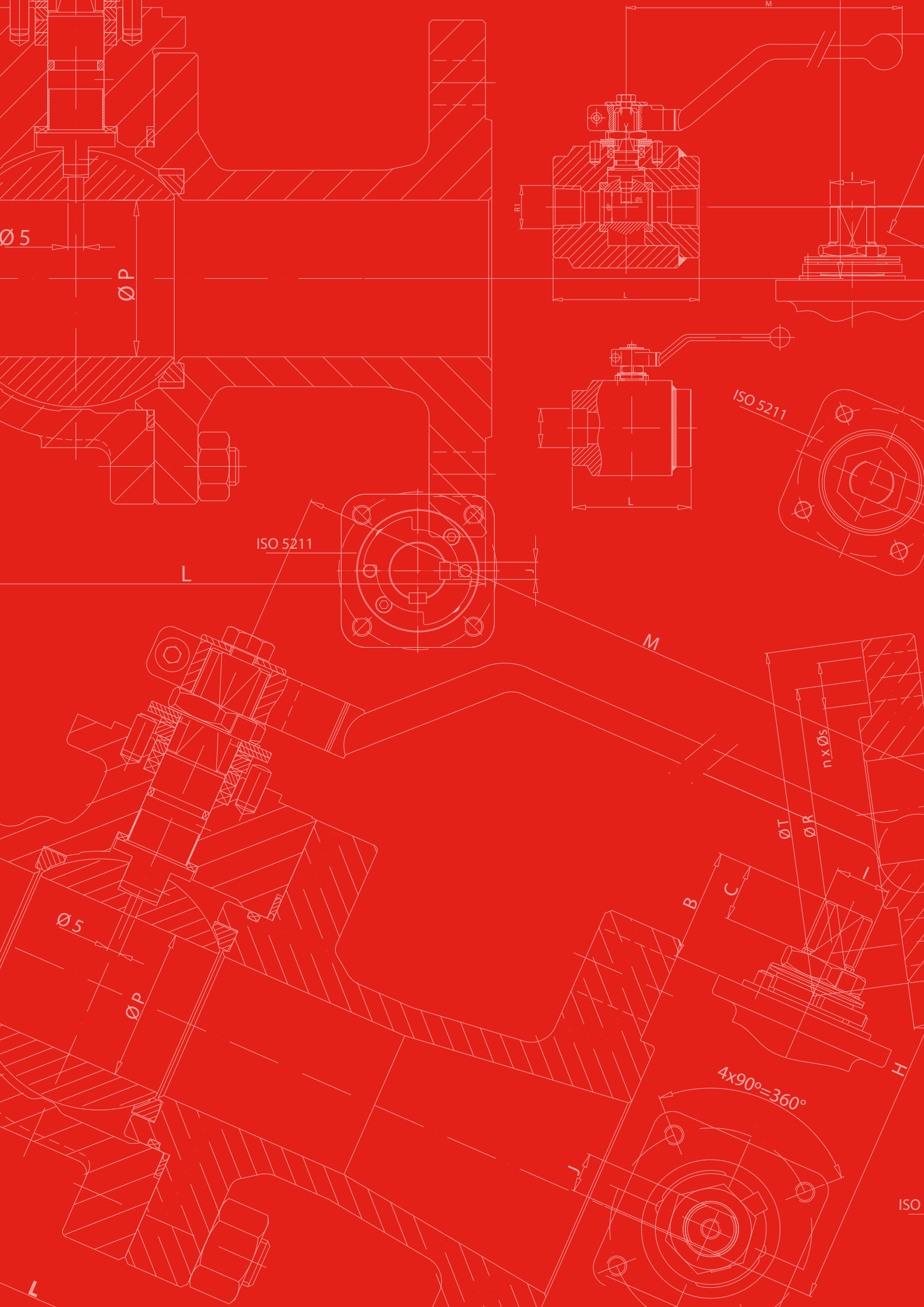



| INDEX |

2

JC VALVES

The company

5

GENERAL HIGHLIGHTS

6

METAL SEATED BALL VALVES

22

TRUNNION MOUNTED BALL VALVES

30

FLOATING ASME BALL VALVES

36

3 PIECE FORGED BALL VALVES

40

MONOBLOCK VALVES

44

SEMI-TRUNNION BALL VALVES

48

FLOATING EN-DIN BALL VALVES

54

FLOATING 3-WAY BALL VALVES

58

SPECIAL CONSTRUCTIONS



The quality option



"We make valves since 1968"

JC Fábrica de Válvulas S.A.U., established in 1968, is a multinational company specialised in the manufacture and sale of high quality industrial valves.

The expertise and know how acquired over the years coupled with the continued investments in the design of valves, has made JC a world renowned company in the field of valve applications.

» Market sectors

JC develops and designs valves for all applications, but the main focus is in Oil & Gas, Chemical, Petrochemical, Pulp & Paper and Energy sectors.



Oil



Chemical



Gas



Pulp & Paper



Petrochemical



Energy



» JC World Wide

JC Valves provides world wide coverage thanks to the strategic locations of its factories and offices:



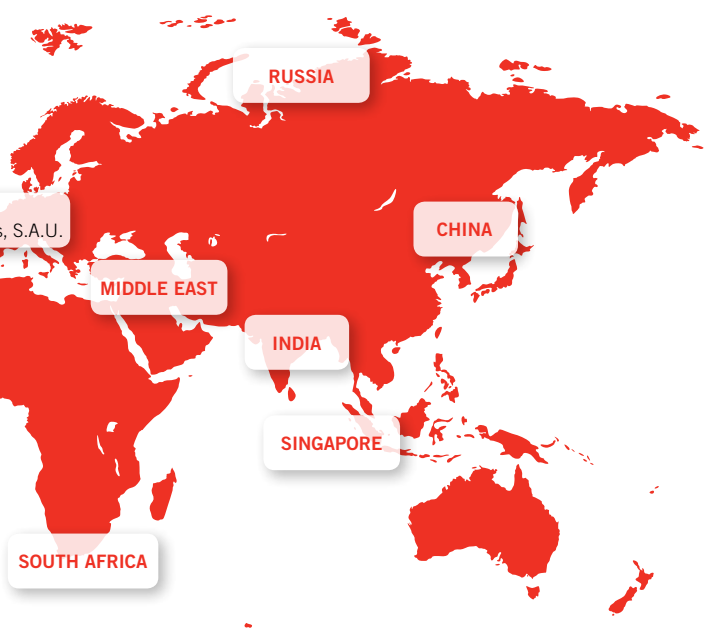

» Global services

JC Fábrica de Válvulas S.A.U. offers its customers a world wide service, from technical advice to choose the right valve up to the design and manufacture of custom built valves to meet special service requirements.

Our R+D department is always ready to find solutions for severe applications and our global distribution network offers quick availability of JC valves and an efficient after sales service.





The quality option

» Quality assurance

JC Valves are designed and produced to meet the major international standards and we take great care and put a lot of emphasis on QUALITY, which provides our customers with a total guarantee and trouble free operation of their process. And in addition, we take great care to make our facilities and our products Environment friendly.

JC Quality Assurance System

- ISO 9001 certified by BV
- API Q1 certified by the AMERICAN PETROLEUM INSTITUTE
- PED 2014 / 68 / UE certified by BV

Products Approvals

- API 6D and API 600 certified by the AMERICAN PETROLEUM INSTITUTE
- CE Marking in accordance with PED 2014 / 68 / UE certified by BV
- Fire Safe according to ISO 10497, API 607 and API 6FA
- TR CU 010, TR CU 012, TR CU 032 for Russian market
- SIL 3 (Safety Integrity Level) certified by BV
- ATEX
- EN 13774
- TA-LUFT, ISO-EN 15848-1

Environmental Certifications

- ISO 14001 certified by BV



API 6D
6D-0197



API 600
600-0016



PED 2014/68/UE

FUGITIVE
EMISSIONS
EN-ISO 15848-1



TP TC 010/2011
TP TC 012/2011
TP TC 032/2013

FIRE SAFE
ISO 10497
API 607
API 6FA



TA-LUFT



GENERAL HIGHLIGHTS

- » Full and Reduced bore
- » Floating and Trunnion mounted ball
- » Soft and Metal seats
- » Castings Quality as per ASME B16.34 Mandatory Appendix I to IV in ASME valves and Severity Levels S3-V3 to DIN 1690 and EN 10203 in EN-DIN valves
- » Polished ball Ra 1 in soft seated valves (in metal seated valves ball is lapped); grinded stem Ra 1.6
- » Full traceability of shell components, upon request, ball and stem as per EN 10204 3.1
- » Antistatic device integral with the stem
- » Viton A, Aflas or Kalrez primary stem seal and secondary graphite packing
- » NACE MR.01.75 wetted parts and bolting as Standard
- » Fire safe as standard construction ISO 10497, API 607 and API 6FA
- » Fugitive emissions EN-ISO 15848-1
- » TA-LUFT VDI 2440
- » SIL 3 (Safety Integrity level 3)

| BALL VALVES |

METAL SEATED

½" - 24" | Class 150 - Class 1500
DN 15 - DN 300 | PN 16 - PN 40



JC offers also a large range of metal seated ball valves for different services (slurries, pulp and liquors, high temperature, abrasive or sticking fluids, control).

- » **Bubble tight sealing up to 327 °C and Class V up to 500 °C**
- » **Low coefficient of friction**
- » **Excellent sliding and running properties**
- » **Hardens the complete surface of ball and seats**

WHY METAL SEATED BALL VALVES?

METAL SEATED BALL VALVES ARE MAINLY USED FOR HEAVY DUTY APPLICATIONS SUCH AS:

- » **High temperatures: above 260 °C**
the use of soft seats is not recommended.
- » **Abrasive media: even small particles can damage soft seats.**
- » **High Velocity in opening/closing cycles: this action can perfectly deform the soft ring and destroy the seat.**



HARDERING TREATMENTS

CT-70

Max. Temperature: 550 °C
 Corrosion Resistance: Medium
 Abrasion Resistance: High

Is a Tungsten Carbide coating in a metallic matrix bonded. Mechanically to the base material by HVOF methods. This treatment gives a very good resistance to abrasion and impact and is suitable to work upon 550 °C.



CC-60

Max. Temperature: 800 °C
 Corrosion Resistance: High
 Abrasion Resistance: High

Is a Chromium Carbide coating in a nickel-chrome base in a metallic matrix bonded mechanically to the base material by HVOF methods. This treatment gives a very good resistance to abrasion and is the best choice for severe corrosion applications. It is suitable to work up to 800 °C.



HT-65

Max. Temperature: 500 °C
 Corrosion Resistance: Medium
 Abrasion Resistance: Medium

This is an exclusive treatment developed by JC with two main advantages, first all the ball and seat surface is hardened and second there is no additional overlay on the seat surface. This gives a very good tightness and a lower torque. The surface is hardened to 70 Rockwell C and it is valid to work upto 500 °C.



DIFFERENT SEAT DESIGNS

Metallic Seat
with O'ring

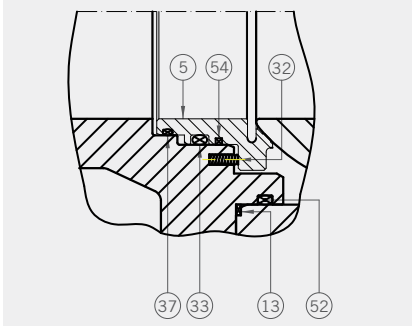

- ⑤ Seat
- ③② Helical spring
- ③③ ③⑦ O'rings
- ①③ ⑤④ Graphite gasket
- ⑤② O'ring

Metallic Seat
with Graphite

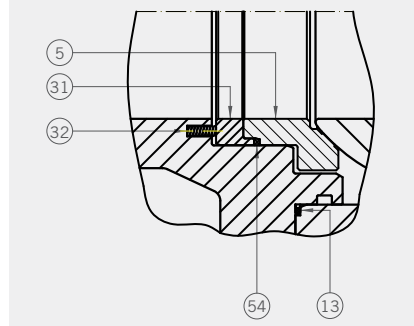

- ⑤ Seat
- ①③ Spiralwound
- ③① Seat carrier
- ③② Helical spring
- ⑤④ Graphite gasket

Metallic Seat
for Floating Valves

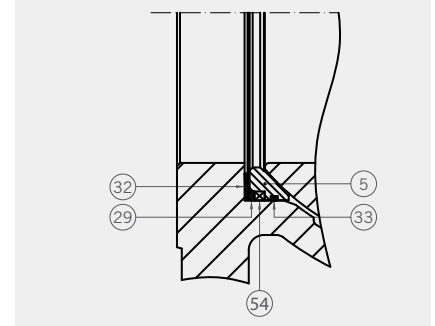

- ⑤ Seat
- ②⑨ Washer
- ③③ O'ring
- ③② Belleville spring
- ⑤④ Graphite gasket

RANGE OF METAL SEATED BALL VALVES

JC can produce the following metal seated ball valves:

Pressure Class	Floating	Monoblock	Trunnion
150	1/2" up to 8"	-	2" up to 24"
300	1/2" up to 4"	-	2" up to 24"
600	1/2" up to 2"	-	2" up to 24"
800	-	1/2" up to 2"	-
900	-	-	2" up to 12"
1500	-	1/2" up to 2"	2" up to 8"

PRODUCTION OF METAL SEATED BALL VALVES

Metal seated ball valves are mainly used for heavy duty applications.

One of the main advantages of using JC metal seated ball valves is the fact that we can transform a soft seated stock valves into a metal seated valve.

THE STEPS TO BE DONE ARE:

- » Re-machining of the body.
- » Lapping of the ball and seats.
- » Hardening treatment to ball and seats.
- » Final adjustment of the ball with its seats.
- » Assembly and test.



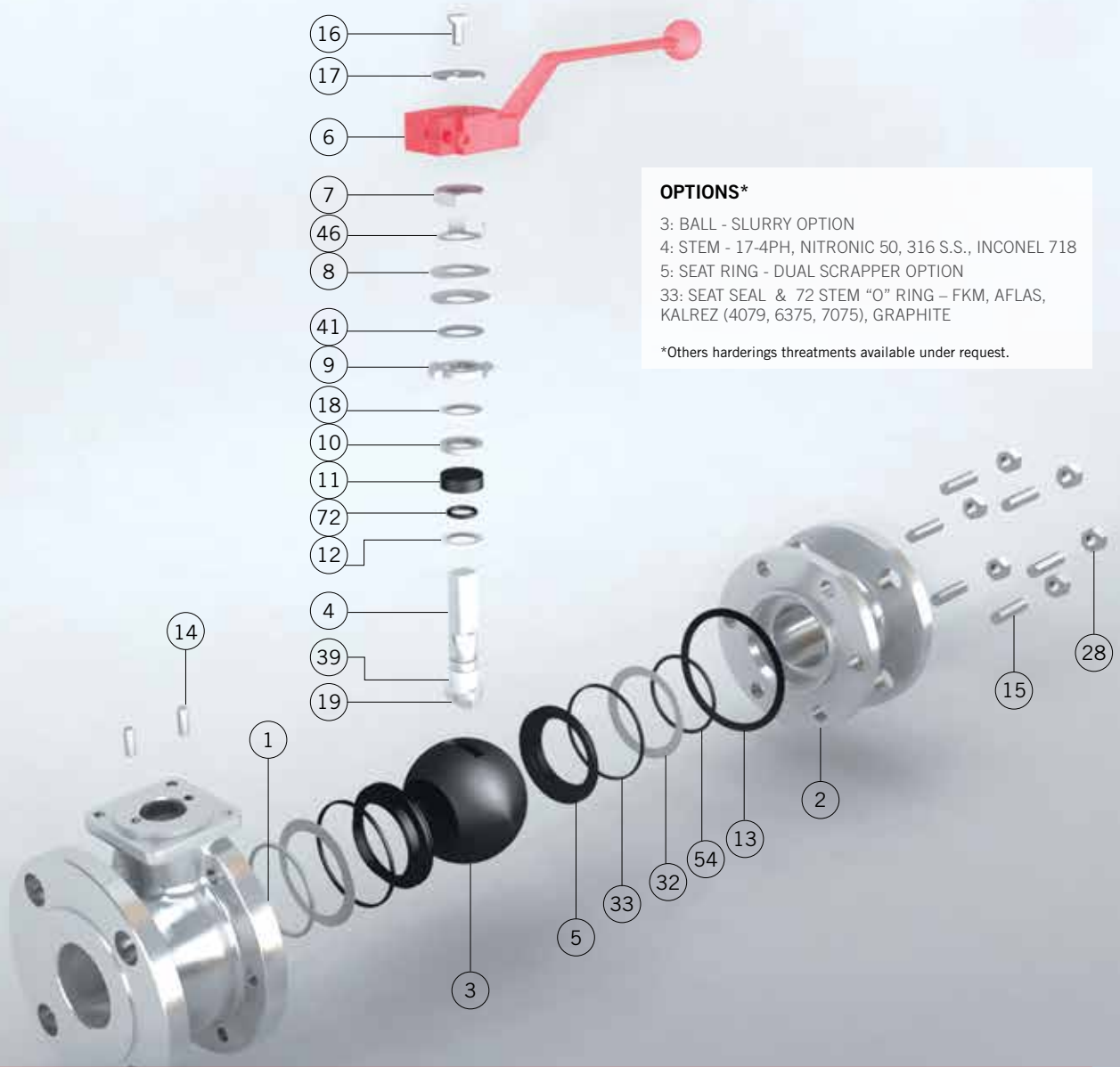

OPTIONS*

- 3: BALL - SLURRY OPTION
- 4: STEM - 17-4PH, NITRONIC 50, 316 S.S., INCONEL 718
- 5: SEAT RING - DUAL SCRAPER OPTION
- 33: SEAT SEAL & 72 STEM "O" RING – FKM, AFLAS, KALREZ (4079, 6375, 7075), GRAPHITE

*Others hardenings treatments available under request.

Materials		EN-DIN		ASME	
		3516 AIM 3540 AIM	3516 IIM 3540 IIM	3515 AIM 3530 AIM	3515 IIM 3530 IIM
Item	Description	Material		Material	
1	Body	1.0619	1.4408	A216 Gr.WCB (C≤0,25%)	A351 Gr. CF8M
2	Body connector	1.0619	1.4408	A216 Gr.WCB (C≤0,25%)	A351 Gr. CF8M
3	Ball	A182 F316 or A351Gr. CF8M (Treatments CT-70, CC-60 or HT-65)		A182 F316 or A351Gr. CF8M (Treatments CT-70, CC-60 or HT-65)	
4	Stem	See options		See options	
5	Seat ring	A182 F316 or A351Gr. CF8M (Treatments CT-70, CC-60 or HT-65)		A182 F316 or A351Gr. CF8M (Treatments CT-70, CC-60 or HT-65)	
6	Wrench	Nodular Iron		Nodular Iron	
7	Gland nut	Zinc plated carbon steel	AISI 303	Zinc plated carbon steel	AISI 303
8	Disk spring	Carbon steel	ENP Carbon Steel	Carbon steel	ENP Carbon Steel
9	Stop plate	Carbon steel	AISI 304	Carbon steel	AISI 304
10	Gland	AISI 303	AISI 316	AISI 303	AISI 316
11	Gland packing	Graphite		Graphite	
12	Stem thrust seal	316 S.S. + HT65		316 S.S. + HT65	
13	Body connector seal	AISI 316L +Graphite		AISI 316L + Graphite	
14	Stop pin	Carbon St.	Stainless St.	Carbon St.	Stainless St.
15	Stud (DN 32 to DN 100)	A4-70		A193Gr. B7M Zinc dichromate	A193 Gr. B8M
16	Bolt	DIN 933 A4-70		DIN 933 A4-70	
17	Washer	Zinc plated carbon steel	AISI 304	Zinc plated carbon steel	AISI 304
18	Thrust washer	316 S.S. + HT65		316 S.S. + HT65	
19	Antistatic device	Stainless St.		Stainless St.	
28	Nut (DN 32 to DN 100)	A4-70		A194 Gr. 2HM Zinc dichromate	A194 Gr. 8M
32	Seat disk spring	Inconel 718		Inconel 718	
33	Seat Ring	See options		See options	
39	Stem bushing	25% G.F. PTFE		25% G.F. PTFE	
41	Spacer (DN 40 to DN200)	Carbon steel	AISI 304	Carbon steel	AISI 304
46	Locking washer	AISI 304		AISI 304	
54	Seat Seal	Graphite		Graphite	
72	Stem "O" Ring	See options		See options	

EN-DIN 3516 / 3540

PN 16 / 40

Full Bore

PN 16. From DN 65 to DN 200

PN 40. From DN 15 to DN 150

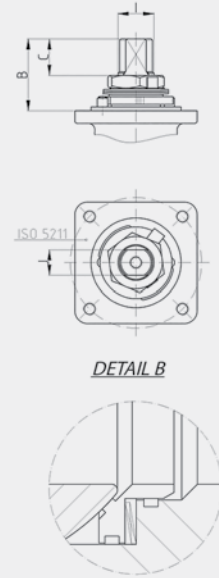
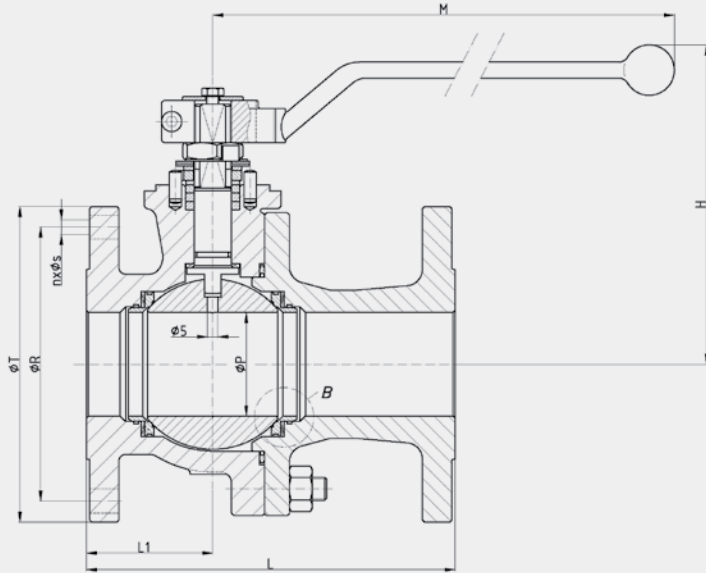

(*) Dimensions of diameters of drills ISO 5211 refer to table from page 60.

Pressure - Temperature

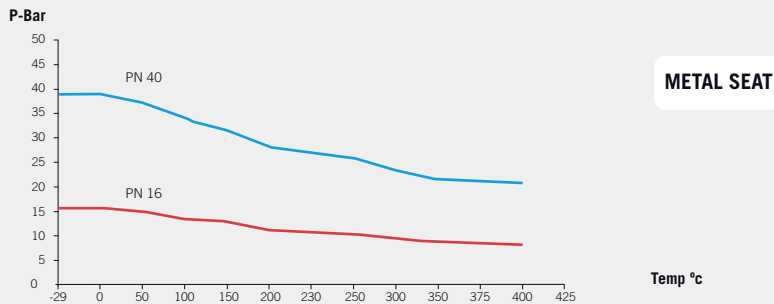

Fig. 3516 (PN 16)

DN	ØP	L	L1	ØR	n x ØS	ØT	H	M	ISO 5211	B	C	I	J	WEIGHT ₃₅₁₆	TORQUE	Kv
65	65	170	76	145	4x18	185	169	348	F07	44	19,7	M22x1.5	16	16	160	550
80	80	180	82	160	8x18	200	207	445	F10	44,5	19,7	M25x1.5	18	22	220	1000
100	100	190	90	180	8x18	220	231	495	F10	56,5	29,2	M28x1.5	20	32	280	1650
125	125	325	120	210	8x18	250	262	698	F12	56	27,6	M35x2	25	52,5	775	3000
150	151	350	135	240	8x22	285	298	698	F12	68	38,5	M40x2	29	76	990	4200
200	203	400	200	295	12x22	340	352	868	F14	72	39	M45x2	32	111	1200	9000

Fig. 3540 (PN 40)

DN	ØP	L	L1	ØR	n x ØS	ØT	H	M	ISO 5211	B	C	I	J	WEIGHT ₃₅₄₀	TORQUE	Kv
15	15	115	53	65	4x14	95	110	164	F05	11,2	5,7	M12x1.5	9	2,8	26	20
20	20	120	52	75	4x14	105	117	164	F05	14,7	9,2	M12x1.5	9	3,6	35	40
25	25	125	49	85	4x14	115	129	164	F05	22,7	10,2	M12x1.5	9	5	40	75
32	32	130	54	100	4x18	140	131	210	F05	32	13,7	M16x1.5	12	7	60	130
40	40	140	55	110	4x18	150	148	213	F07	41,5	19,2	M18x1.5	13	9	90	170
50	50	150	61	125	4x18	165	155	213	F07	41,5	19,2	M18x1.5	13	12	120	270
(1) 65	65	170	76	145	8x18	185	169	348	F07	44	19,7	M22x1.5	16	17	160	550
(1) 80	80	180	75	160	8x18	200	207	445	F10	44,5	19,7	M25x1.5	18	23	220	1000
(1) 100	100	190	91	190	8x22	235	231	495	F10	56,5	29,2	M28x1.5	20	35	280	1650
(1) 125	125	325	120	220	8x26	270	262	698	F12	56	27,6	M35x2	25	57	775	3000
(1) 150	151	350	135	250	8x26	300	298	698	F12	68	38,5	M40x2	29	83,5	990	4200

(*) Dimensions in mm and weight in kg.

(**) Weights and dimensions can be changed without notice.

(1) Limited to 16 bar.

ASME 3515 / 3530

Class 150 / 300

Full Bore

Class 150. From ½" to 8"

Class 300. From ½" to 6"

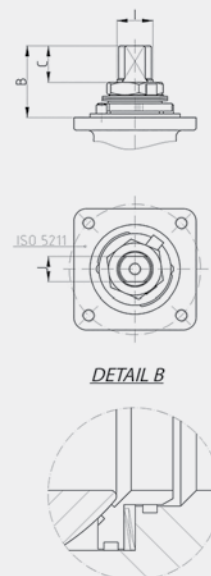
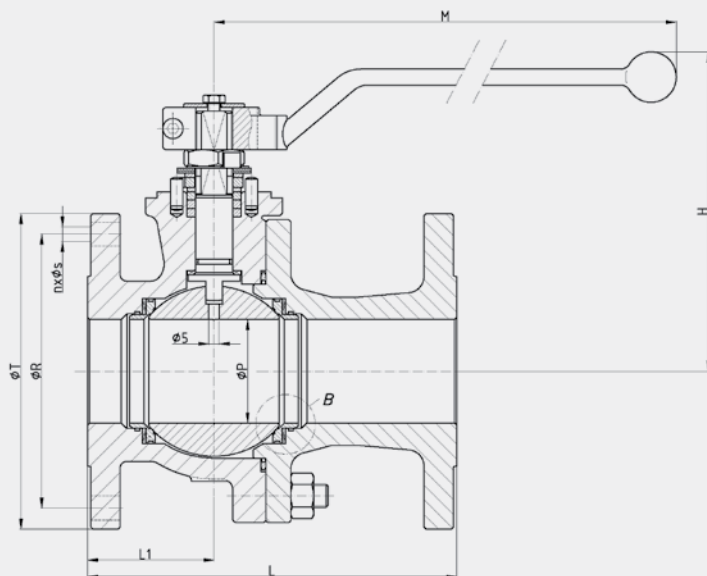

(*) Dimensions of diameters of drills ISO 5211 refer to table from page 60.

Pressure - Temperature

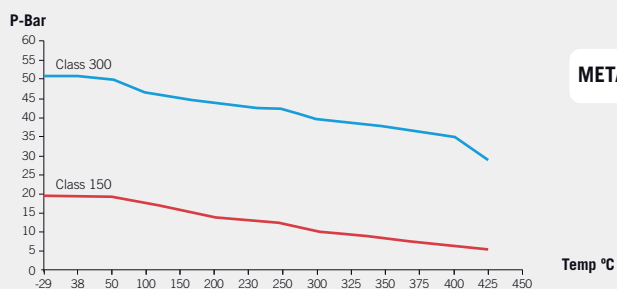

METAL SEAT



Fig. 3515 (Class 150)

DN	øP	L	L1	øR	n x øS	øT	H	M	ISO 5211	B	C	I	J	WEIGHT	TORQUE	Kv
15 (½")	15	108	47	60,3	4x15,9	90	110	164	F05	11,2	5,7	M12x1.5	9	2	22	20
20 (¾")	20	117	50	69,9	4x15,9	100	117	164	F05	14,7	9,2	M12x1.5	9	3	32	40
25 (1")	25	127	52	79,4	4x15,9	110	129	164	F05	22,7	10,2	M12x1.5	9	3,5	39	75
40 (1½")	40	165	65	98,4	4x15,9	125	148	213	F07	41,5	19,2	M18x1.5	13	8	59	170
50 (2")	50	178	61	120,7	4x19	150	155	213	F07	41,5	19,2	M18x1.5	13	11	100	270
65 (2½")	65	190	75	139,7	4x19	180	169	348	F07	44	19,7	M22x1.5	16	16	140	550
80 (3")	80	203	79	152,4	4x19	190	207	445	F10	44,5	19,7	M25x1.5	18	23	260	1000
100 (4")	100	229	90	190,5	8x19	230	231	495	F10	56,5	29,2	M28x1.5	20	38	440	1650
150 (6")	151	394	174	241,3	8x22,2	280	298	698	F12	68	38,5	M40x2	29	88	800	4200
200 (8")	203	457	200	298,5	8x22,2	345	352	868	F14	72	39	M45x2	32	155	1100	9000

Fig. 3530 (Class 300)

DN	øP	L	L1	øR	n x øS	øT	H	M	ISO 5211	B	C	I	J	WEIGHT	TORQUE	Kv
15 (½")	15	140	60	66,7	4x15,9	95	110	164	F05	11,2	5,7	M12x1.5	9	3	22	20
20 (¾")	20	152	65	82,6	4x19	115	117	164	F05	14,7	9,2	M12x1.5	9	4	40	40
25 (1")	25	165	70	88,9	4x19	125	129	164	F05	22,7	10,2	M12x1.5	9	5	45	75
40 (1½")	40	190	80	114,3	4x22,2	155	148	213	F07	41,5	19,2	M18x1.5	13	11	80	170
50 (2")	50	216	83	127	8x19	165	155	213	F07	41,5	19,2	M18x1.5	13	14	150	270
(1) 80 (3")	80	283	118	168,3	8x22,2	210	207	445	F07	44,5	19,7	M25x1.5	18	32	250	550
(1) 100 (4")	100	305	133	200	8x22,2	255	231	495	F10	56,5	29,2	M28x1.5	20	52	500	1000

(*) Dimensions in mm and weight in kg.

(**) Weights and dimensions can be changed without notice.

(1) Limited to 16 bar.

| BALL VALVES |

METAL SEATED UDV

1/2" - 2" | Class 800 - Class 1500

The Ultimate Drain Valve (UDV) it is a high temperature special design. The valve has got a monobloc welded body and it is reduced bore. This valve is designed to support high temperatures at high pressures.

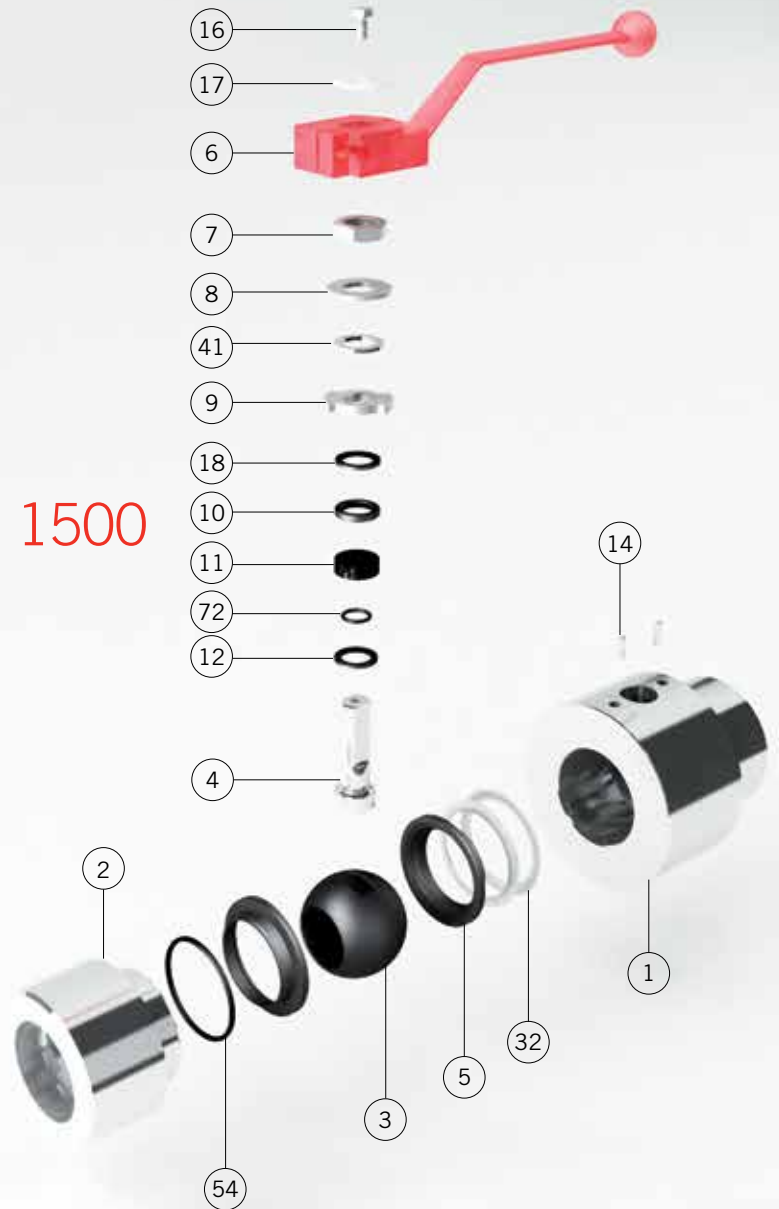

Materials

METAL SEATED UDV

Item	Description	C.S. BODY	S.S. BODY
1	Body	A 105	A 479 Type 316
2	Body connector	A 105	A 479 Type 316
3	Ball		AISI 316 + HT-65 (*)
4	Stem		17-4 PH + HT-65 (*)
5	Metallic seat		AISI 316 + HT-65
6	Wrench		GGG-40
7	Gland nut	Zinc plated carbon st.	AISI 303
8	Disk spring	Carbon St.	E.N.P. Carbon St.
9	Stop plate	Carbon St.	AISI 304
10	Gland		AISI 316 + HT-65
11	Gland packing		Graphite
12	Stem thrust seal		AISI 316 + HT-65
14	Stop pin	Carbon St.	Stainless St.
16	Bolt	DIN 933 5.6 Zinc plated	DIN 933 A2
17	Washer	Carbon St.	Stainless St.
18	Thrust washer		AISI 316 + HT-65
32	Disk spring		Inconel 718
41	Spacer	Carbon St.	Stainless St.
54	Seat gasket		Graphite
72	O'ring		AFlas

(*) Other materials under request.

UDV CLASS 800 & 1500 AIM & IIM TYPE **Class 800 / 1500** **Reduced Bore**

Class 800. From ½" to 2" Class 1500. From ½" to 2"

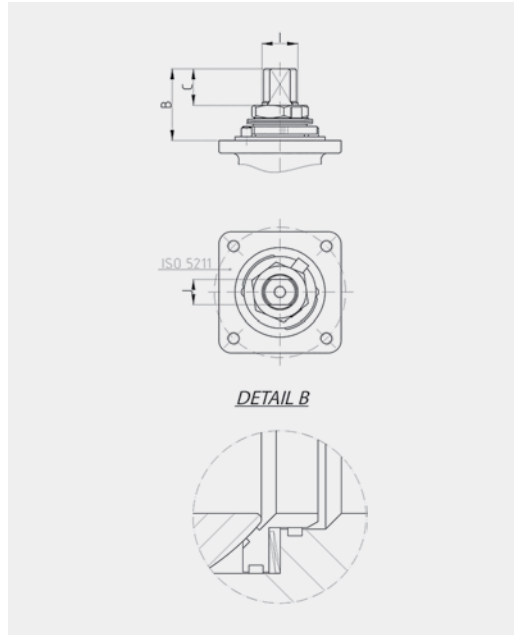
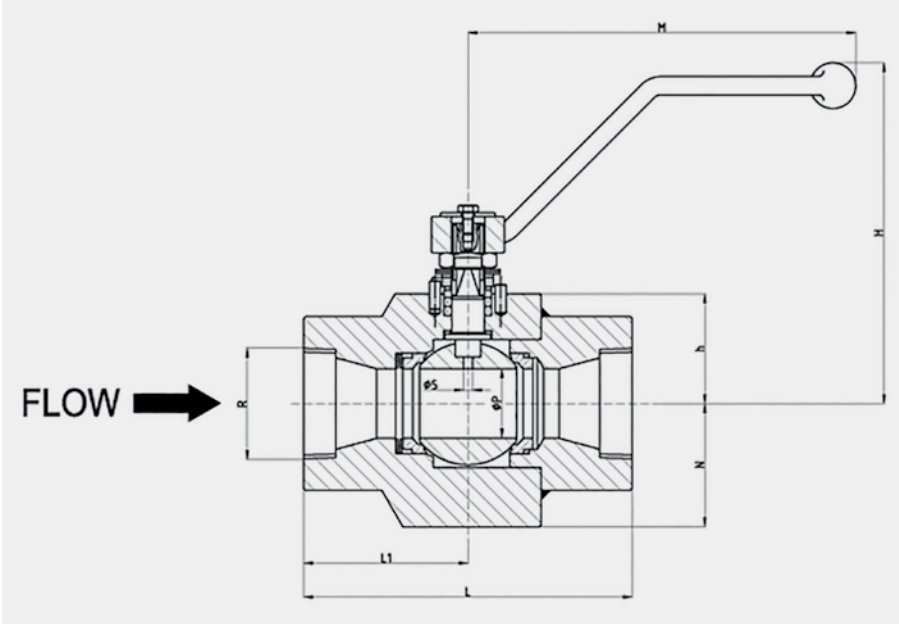

(*) Diameter of drills ISO 5211 = n x F.

Pressure - Temperature

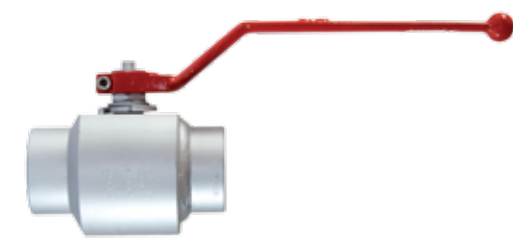
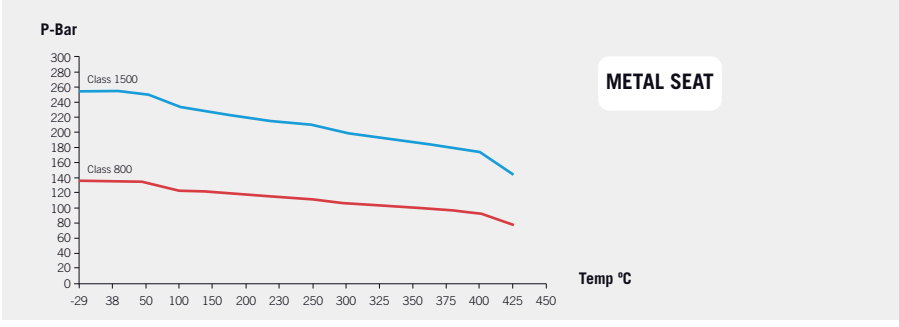

Fig. UDV (Class 800)

DN	ØP	L	L1	R	N	h	H	M	ISO 5211	B	C	I	J	WEIGHT	TORQUE	Kv
½"	15	90	45	NPT	37,5	32	102	164	F04	18,4	7,8	M12 x1,5	9	3,5	30	11
¾"	15	110	55	NPT	37,5	32	102	164	F04	18,4	7,8	M12 x1,5	9	4,5	30	11
1"	20	120	60	NPT	42,5	35,5	106	164	F05	20	8,5	M12 x1,5	9	5	37	14
1½"	28	150	75	NPT	60	50	111	210	F05	31,5	15,5	M16 x1,5	12	6	102	30
2"	36	180	90	NPT	67,5	60	128	213	F07	38,5	19	M18 x1,5	13	10	173	72

Fig. UDV (Class 1500)

DN	ØP	L	L1	R	N	h	H	M	ISO 5211	B	C	I	J	WEIGHT	TORQUE	Kv
½"	15	90	45	NPT	37,5	32	102	164	F04	18,4	7,8	M12x1,5	9	3,5	39	11
¾"	15	110	55	NPT	37,5	32	102	164	F04	18,4	7,8	M12x1,5	9	4,5	39	11
1"	20	120	60	NPT	42,5	35,5	106	164	F05	20	8,5	M12x1,5	9	5	54	14
1½"	28	150	75	NPT	60	50	111	210	F05	31,5	15,5	M16x1,5	12	6	161	30
2"	36	180	90	NPT	67,5	60	128	213	F07	38,5	19	M18x1,5	13	10	287	72

(*) Dimensions in mm and weight in kg.
(**) Weights and dimensions can be changed without notice.

| BALL VALVES |

METAL SEATED CAST TRUNNION

2" - 24" | Class 150 - Class 600

Materials METAL TO METAL TRUNNION

Item	Description	AIM	IIM
1	Body	A 216 Gr. WCB (C ≤ 0.25%)	A 351 Gr. CF8M
2	Body connector	A 216 Gr. WCB (C ≤ 0.25%)	A 351 Gr. CF8M
3	Ball	A182 F316 or A351Gr. CF8M (Treatments CT-70, CC-60 or HT-65)	
4	Stem	17-4 PH or Nitronic 50	
5	Seat ring	Tp.316 + HT70	
7	Gland nut	Zinc Plated Carbon Steel	AISI-303
8	Disk spring / Spring	Carbon St. *	E.N.P. Carbon St. *
9	Stop plate	Carbon St.	AISI-304
10	Gland ring	AISI-303 + HT-65	AISI-316 + HT-65
10.1	Gland	AISI-303	AISI-316
11	Gland packing	Graphite	
12	Stem thrust seal	AISI-316 + HT-65	
13	Body connector seal	AISI-316L + Graphite	
14	Stop pin	Carbon St.	Stainless St.
15	Stud	A 193 Gr. B7M Zinc dichromate	A 193 Gr. B8M **
18	Thrust washer	50% S.S. PTFE	
19	Antistatic device	Stainless St.	
21 / 21a	Ball trunnion	A 351 Gr. CF8M	
22 / 22a	Trunnion bearing	AISI-316 + PTFE	
26	Bolt	DIN 912 8.8 Zinc Plated	DIN 912 A2
28	Nut	A 194 Gr. 2HM Zinc dichromate	A 194 Gr. 8M **
32	Spring	Inconel - 750	
33	O' Ring	FKM -- Note 1 --	
35	Spring carrier	A 351 Gr. CF8M	
39	Stem bushing	25% G.F. PTFE	
39.1	Stem bushing	AISI-316 + PTFE -- Note 2 & Note 3 --	
41	Spacer	Carbon St.	Stainless St.
43	Key	AISI-316	
46	Locking washer	AISI-304	
47	Key	Carbon St.	
50	Drain plug	A 105	AISI-316
50.1	Vent plug	A 105	AISI-316
52	O' Ring	FKM -- Note 1 & Note 2 --	
54	Seat carrier seal	Graphite	
58	Spring protection	Carbon St.	Stainless St.
72	O' Ring	FKM -- Note 1 --	
75	Stem bushing	AISI-316 + PTFE -- Note 2 & Note 3 --	
89	Identification plate	Stainless St.	
471	Retainer	Carbon St.	Stainless St.

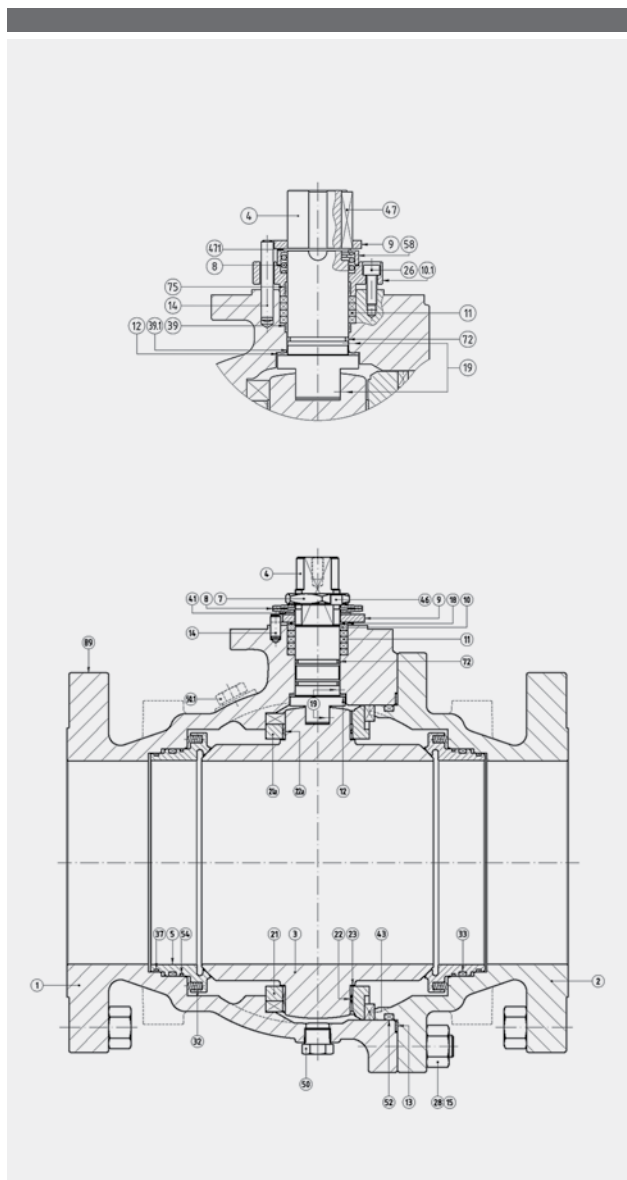

(*) On request Inconel X-750.

(**) On request B7M / 2HM Zinc Plated & Bichromated.

Note 1: Depending on design conditions AFLAS, KALREZ or KALREZ Spectrum.

Note 2: Only DN-350 & 400 and all Fig.2560.

Note 3: Over 350°C Steel Inconel + HT-625

CAST TRUNNION METAL 2515 / 2530 / 2560

Class 150 / 300 / 600

Full Bore

Class 150. From 2" to 16"

Class 300. From 2" to 16"

Class 600. From 2" to 12"

DN 50 (2") to DN-250 (10") Class-150 & 300
DN-50 (2") to DN-100 (4") Class-600

DN 300 (12") to DN-400 (16") Class-150 & 300
DN-150 (6") to DN-300 (12") Class-500

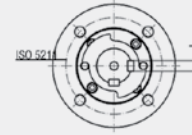
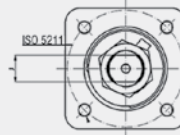
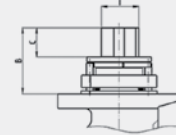
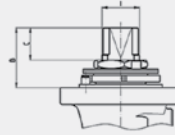
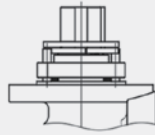
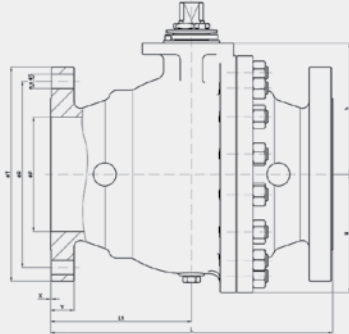

(*) Dimensions of diameters of drills ISO 5211 refer to table from page 60.

Pressure - Temperature

P-Bar

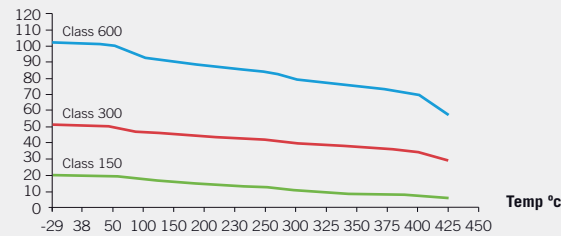

METAL SEAT



Fig. 2515 (Class 150)

DN	ØP	L	L1	ØR	n x ØS	ØT	h	N	ISO 5211	B	C	I	J	K	WEIGHT	TORQUE
50 (2")	50	178	78.5	120.7	4x19	150	84	80	F07	42	17	M22x1.5	16	-	13	80
80 (3")	80	203	87	152.4	4x19	190	126	-	F10	55	27	M28x1.5	20	-	22	220
100 (4")	100	229	101	190.5	8x19	230	152	120	F12	56	27	M35x2	25	-	39	340
150 (6")	151	394	197	241.3	8x22.2	280	212	168	F14	70	36	M45x2	32	-	98	720
200 (8")	203	457	230	298.5	8x22.2	345	233	208	F14	70	37	M45x2	32	-	124	1300
250 (10")	254	533	267	362	12x25.4	405	256	243	F14	70	37	M45x2	32	-	175	1883
300 (12")	305	610	305	431.8	12x25.4	485	297	287.5	F14	106	58	50	14	53.5	295	2620
350 (14")	337	686	343	476.3	12x28.5	535	333	323	F16	103	49	60	18	64.2	580	2446
400 (16")	388	762	381	539.8	16x28.5	595	412	358	F25	159	103	90	25	95.3	750	3160

Fig. 2530 (Class 300)

DN	ØP	L	L1	ØR	n x ØS	ØT	h	N	ISO 5211	B	C	I	J	K	WEIGHT	TORQUE
50 (2")	50	216	84	127	8x19	165	84	-	F07	42	17	M22x1.5	16	-	16	190
80 (3")	80	283	115	168.3	8x22.2	210	126	-	F10	55	27	M28x1.5	20	-	33	360
100 (4")	100	305	133	200	8x22.2	255	152	-	F12	56	27	M35x2	25	-	43	640
150 (6")	151	403	202	269.9	12x22.2	320	212	173	F14	70	36	M45x2	32	-	113	1290
200 (8")	203	502	252	330.2	12x25.4	380	233	210	F14	70	37	M45x2	32	-	157	2162
250 (10")	254	568	284	387.4	16x28.5	445	257	253	F14	70	37	M45x2	32	-	263	4100
300 (12")	305	648	315	450.8	16x31.8	520	310	300	F16	103	49	60	18	64.2	480	5670
350 (14")	337	762	381	514.4	20x31.8	585	333	331	F16	103	49	60	18	64.2	655	6030
400 (16")	388	838	419	571.5	20x34.9	650	412	365	F25	159	103	90	25	95.3	890	7200

Fig. 2560 (Class 600)

DN	ØP	L	L1	ØR	n x ØS	ØT	h	N	ISO 5211	B	C	I	J	K	WEIGHT	TORQUE
50 (2")	50	292	96	127	8x19	165	84	-	F07	42	17	M22x1.5	16	-	20	270
80 (3")	80	356	140	168.3	8x22.2	210	126	113	F10	55	27	M28x1.5	20	-	41	560
100 (4")	100	432	160	215.9	8x25.2	275	152	-	F12	56	27	M35x2	25	-	77	1240
150 (6")	151	559	246	292.1	12x28.5	355	212	188	F14	97	49	45	14	48.5	192	2500
200 (8")	203	660	315	349.2	12x31.8	420	237	235	F14	113	64	50	14	53.5	329	6060
250 (10")	254	787	340	431.8	16x34.9	510	275	273	F16	103	49	60	18	64.2	460	8300
300 (12")	305	838	404	489	20x34.9	560	345	335	F16	127	73	65	18	69.2	570	9400

(*) Dimensions in mm and weight in kg.
(**) Weights and dimensions can be changed without notice.

| BALL VALVES |

METAL SEATED 3-PIECE FORGED TRUNNION MOUNTED

2" - 24" | Class 150 - Class 1500

A trunnion ball valve has additional mechanical anchoring of the ball at the top and the bottom, suitable for larger and higher pressure valves.

The JC trunnion mounted ball valves are suitable to stand the harsh service conditions often presented in the hydrocarbon industry and in the gas storage and transportation field. In general, they are recommended for tight shut-off in high pressure and double block and bleed applications.



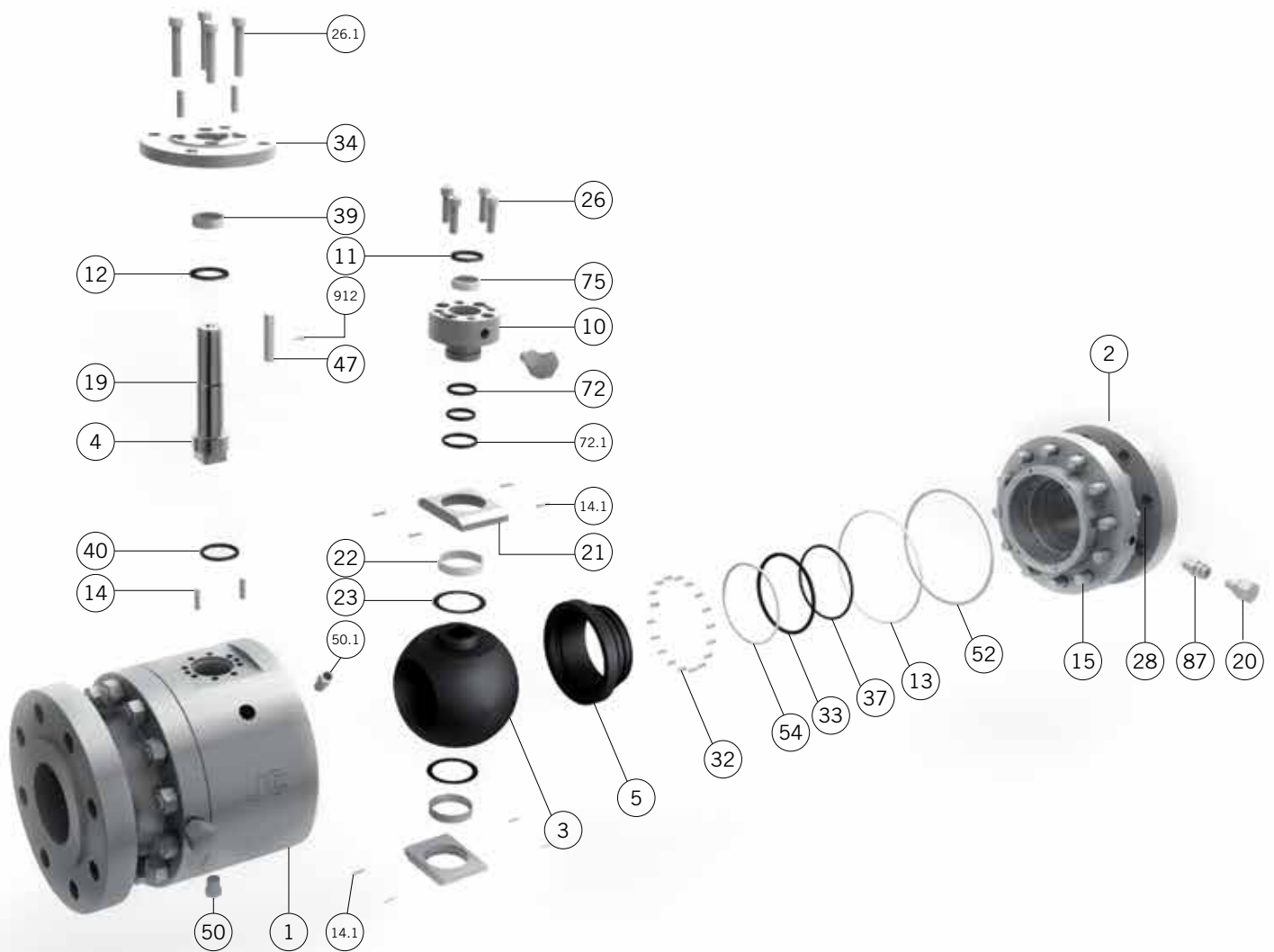

Materials

SERIES 6000(M) & 7000(M)

Item	Description	AIM	LIM	IIM
1	Body	A 105N	A 350 Gr. LF2 Class. 1	A182 F316
2	Body Connector	A 105N	A 350 Gr. LF2 Class. 1	A182 F316
3	Ball		A182 F316 or A351Gr. CF8M (Treatments CT-70, CC-60 or HT-65)	
4	Stem		17-4 PH or Nitronic 50	
5	Seat		A 479 Tp.316 / A182 F316 (Treatments CT-70, CC-60 or HT-65)	
10	Gland	A 105N	A 350 Gr. LF2 Class-1	A 479 Tp.316
11	Gland Packing		Graphite	
12	Stem Thrust Seal		AISI 316 + HT-65	
13	Body Connector Seal		Graphite	
14 / 14.1	Pin	Carbon St.	Carbon Steel	Stainless Steel
15	Stud	A 193 Gr. B7M Zinc dichromate	A 320 Gr. L7M	A 193 Gr. B8M
19	Antistatic Device		Stainless St.	
20	Sealant Injector	Carbon Steel	Carbon Steel	Stainless Steel
21	Ball Trunnion		A 479 Tp.316	
22*	Trunnion Bearing		AISI 316 with inside in PTFE	
23*	Bearing		PTFE	
26 / 26.1	Bolt	A 193 Gr. B7M Zinc dichromate	A 320 Gr. L7M	A 193 Gr. B8M
28	Nut	A 194 Gr. 2HM Zinc dichromate	A 194 Gr. 7M	A 194 Gr. 8M
32	Spring		Inconel - 750	
33*	"O" Ring		AFLAS	
34	Mounting Flange	A 105N	A 350 Gr. LF2 Class-1	A 479 Tp.316
37*	"O" Ring		AFLAS	
39*	Stem Bushing		AISI 316 with inside in PTFE	
40	Gasket		Graphite	
47	Key	Carbon Steel	Carbon Steel	Stainless St.
50	Drain Plug	A 105	A 350 Gr. LF2 Class-1	AISI 316
50.1	Relieve Plug	A 105	A 350 Gr. LF2 Class-1	AISI 316
52*	"O" Ring		AFLAS	
54	Seat Carrier Seal		Graphite	
72* / 72.1	"O" Ring		AFLAS	
75*	Stem Bushing		AISI 316 with inside in PTFE	
87	Check Valve		Stainless St.	
912	Bolt		DIN 912 A2	

(*) In case of extreme high temperature it could be changed to another material.

METAL SEATED FORGED BALL VALVES 6015 / 6030 / 6060 / 6090 / 6050

Full Bore

Class 150.
From 2" to 24" (1)

Class 300.
From 2" to 24" (1)

Class 600.
From 2" to 24" (1)

Class 900.
From 2" to 12" (1)

Class 1500.
From 2" to 8" (1)

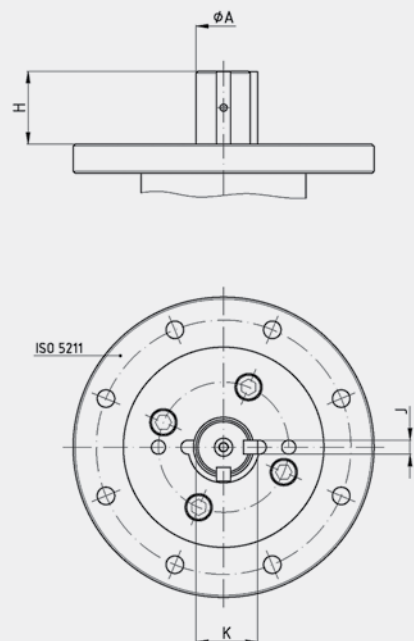
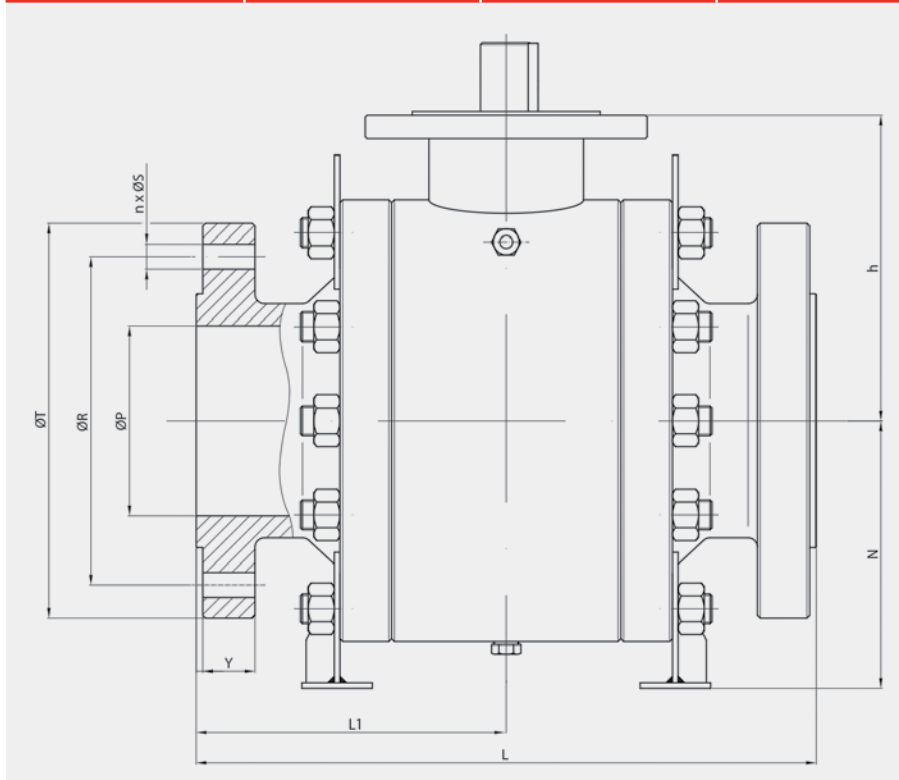

(*) Dimensions of diameters of drills ISO 5211 refer to table from page 60.

Pressure - Temperature

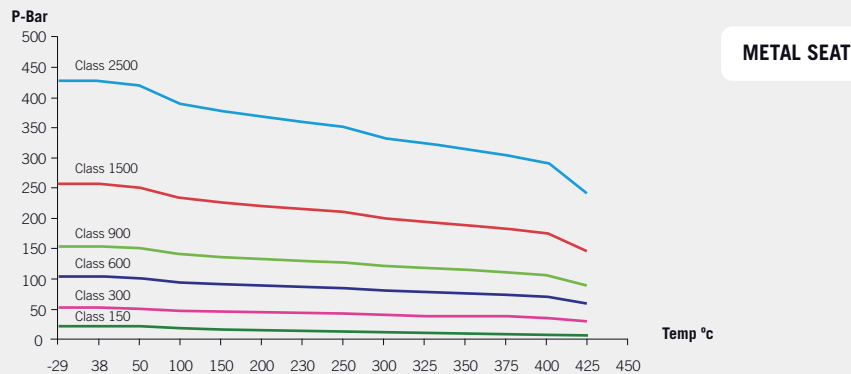

Fig. 6015 (Class 150)

DN	øP	L	L1	øR	n x øS	øT	Y	h	N	ISO 5211	H	øA	J	K	WEIGHT	TORQUE	Kv
2"	49	178	89	120.7	4 x 19	150	14	125	100	F10	36,5	20	8	22,5	24	50	366
3"	76	203	101,5	152.4	4 x 19	190	18	156,5	133,5	F12	37,5	26	10	30	47	97	938
4"	102	229	114,5	190.5	8 x 19	230	22	175	167	F12	54	30	10	34	86	170	1.465
6"	152	394	197	241.3	8 x 22	280	24	269	277	F16	71	39,9	14	48,9	191	457	3.297
8"	203	457	228,5	298.5	8 x 22.2	345	27	325	325	F25	77	49,9	14	58,4	357	845	5.861
10"	254	533	266,5	362	12 x 25.4	405	29	362	319	F25	84,5	59,9	16	67	529	1.396	9.454
12"	305	610	305	431.8	12 x 25.4	485	30	423	399	F25	104	69,9	18	78	794	2.836	13.631
14"	337	686	343	476.3	12 x 28.5	535	33	455	439	F30	119	79,9	22	87,9	1.120	3.411	16.641
16"	387	762	381	539.8	16 x 28.5	595	35	490	472	F30	134	84,9	22	94,9	1.473	4.501	23.554
18"	438	864	432	577.9	16 x 31.8	635	38	542	596	F30	147,5	99,9	28	111,9	1.860	6.543	29.672
20"	488	914	457	635	20 x 31.8	700	41	577	610	F30	147,5	99,9	28	111,9	2.589	8.238	36.633
24"	589	1.067	533,5	749.3	20 x 34.9	815	46	599	692	F40	152	120	32	134	4.302	20.908	52.751

(**) Dimensions in mm and weight in kg.
(**) Weights and dimensions can be changed without notice.
(1) Bigger sizes available under customers request.

Fig. 6030 (Class 300)

DN	øP	L	L1	øR	n x øS	øT	Y	h	N	ISO 5211	H	øA	J	K	WEIGHT	TORQUE	Kv
2"	49	216	108	127	8 x 19	165	21	125	95	F10	36,5	20	8	22,5	28	83	366
3"	76	283	141,5	168.3	8 x 22.2	210	27	156.5	133,5	F12	37,5	26	10	30	61	208	938
4"	102	305	152,5	200	8 x 22.2	255	30	175	167	F12	54	30	10	34	100	380	1.465
6"	152	403	201,5	269.9	12 x 22.2	320	35	269	277	F16	71	39,9	14	48,9	217	1.089	3.297
8"	203	502	251	330.2	12 x 25.4	380	40	325	293	F25	77	49,9	14	58,4	387	2.060	5.861
10"	254	568	284	387.4	16 x 28.5	445	46	362	335	F25	84,5	59,9	16	67	610	3.497	9.454
12"	305	648	324	450.8	16 x 31.8	520	49	423	399	F25	104	69,9	18	78	882	7.256	13.631
14"	337	762	381	514.4	20 x 31.8	585	52	455	439	F30	119	79,9	22	87,9	1.296	8.579	16.641
16"	387	838	419	571.5	20 x 34.9	650	56	490	472	F30	134	84,9	22	94,9	1.687	11.344	23.554
18"	438	914	457	628.6	24 x 34.9	710	59	542	596	F30	147,5	99,9	28	111,9	2.057	16.348	29.672
20"	488	991	495,5	685.8	24 x 34.9	775	62	577	610	F30	147,5	99,9	28	111,9	2.872	20.945	36.633
24"	589	1.143	571,5	812.8	24 x 41.3	915	68	599	673	F40	152	120	32	134	5.525	44.489	52.751

Fig. 6060 (Class 600)

DN	øP	L	L1	øR	n x øS	øT	Y	h	N	ISO 5211	H	øA	J	K	WEIGHT	TORQUE	Kv
2"	49	292	146	127	8 x 19	165	25	125	100	F10	36,5	20	8	22,5	33	153	366
3"	76	356	178	168.3	8 x 22.2	210	32	156,5	138,5	F12	37,5	26	10	30	75	355	938
4"	102	432	216	213.9	8 x 25.4	275	38	175	164	F12	54	30	10	34	136	716	1.465
6"	152	559	279,5	292.1	12 x 28.5	355	48	268,5	277,5	F16	71	44,9	14	51,4	300	2.211	3.297
8"	203	660	330	349.2	12 x 31.8	420	56	325	293	F25	77	54,9	14	61,4	561	4.131	5.861
10"	254	787	393,5	431.8	16 x 34.9	510	64	362	335	F25	84,5	59,9	16	67	828	6.891	9.454
12"	305	838	419	489	20 x 34.9	560	67	423	418	F25	104	69,9	18	78	1.238	13.065	13.631
14"	337	889	444,5	527	20 x 38.1	605	70	455	450	F30	119	79,9	22	87,9	1.532	15.373	16.641
16"	387	991	495,5	603.2	20 x 41.3	685	76	490	504	F30	134	84,9	22	94,9	2.137	20.339	23.554
18"	438	1.092	546	654	20 x 44.5	745	83	542	567,5	F30	147,5	99,9	28	111,9	2.595	29.257	29.672
20"	488	1.194	597	723.9	24 x 44.5	815	89	577	581	F35	147,5	99,9	28	111,9	3.454	37.645	36.633
24"	589	1.397	698,5	838.2	24 x 50.8	940	102	599	694	F40	157,5	119,8	32	133,6	6.250	76.800	52.751

Fig. 6090 (Class 900)

DN	øP	L	L1	øR	n x øS	øT	Y	h	N	ISO 5211	H	øA	J	K	WEIGHT	TORQUE	Kv
2"	51	368	184	165,1	8 x 25.4	215	38,1	120	101	F14	46	29	8	32,5	52	518	366
3"	77	381	190,5	190,5	8 x 25.4	240	38,1	153	124	F16	50	39,9	10	44,5	80	1.193	938
4"	102	457	228,5	235	8 x 31.8	290	44,5	170	151	F25	56	39,9	10	44,5	170	1.843	1.465
6"	152	610	305	317,5	12 x 31.8	380	55,6	214	380	F25	63	44,9	14	51,4	390	3.339	3.297
8"	203	737	368,5	393,7	12 x 38.1	470	63,5	258	428	F25	87	65	16	74,5	640	8.596	5.861
10"	254	838	419	469,9	16 x 38.1	545	69,9	303	489	F25	90	75	20	81	1.070	12.271	9.454
12"	305	965	482,5	533,4	20 x 38.1	610	79,4	348	525	F25	99	85	22	95	1.610	19.382	13.631

Fig. 6050 (Class 1500)

DN	øP	L ⁽²⁾	L1	øR	n x øS	øT	Y	h	N	ISO 5211	H	øA	J	K	WEIGHT	TORQUE	Kv
2"	51	371	185,5	165,1	8 x 25.4	215	38,1	129	107	F14	46	29	8	32,5	55	866	366
3"	77	473	236,5	203,2	8 x 31.8	265	47,7	156	137	F25	55	39,9	10	44,5	105	2.253	938
4"	102	549	274,5	241,3	8 x 34.9	310	54	193	168	F25	56	39,9	10	44,5	205	3.105	1.465
6"	146	711	355,5	317,5	12 x 38.1	395	82,6	242	395	F25	95	60	18	64	525	5.428	3.297
8"	194	841	420,5	393,7	12 x 44.5	485	92,1	292	445	F25	119	75	18	82,9	890	15.333	5.861

(*) Dimensions in mm and weight in kg.

(**) Weights and dimensions can be changed without notice.

(1) Bigger sizes available under customers request.

METAL SEATED FORGED BALL VALVES 7015 / 7030 / 7060 / 7090 / 7050

Reduced Bore

Class 150.
From 2" to 24" (1)

Class 300.
From 2" to 24" (1)

Class 600.
From 2" to 24" (1)

Class 900.
From 2" to 12" (1)

Class 1500.
From 2" to 8" (1)

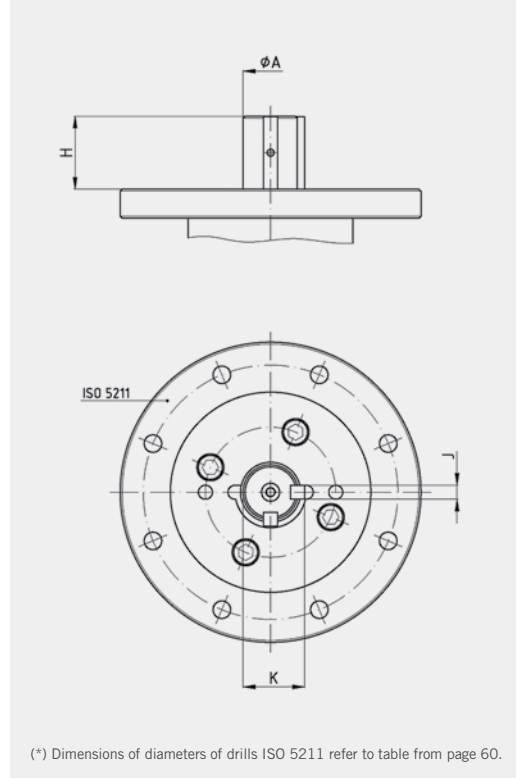
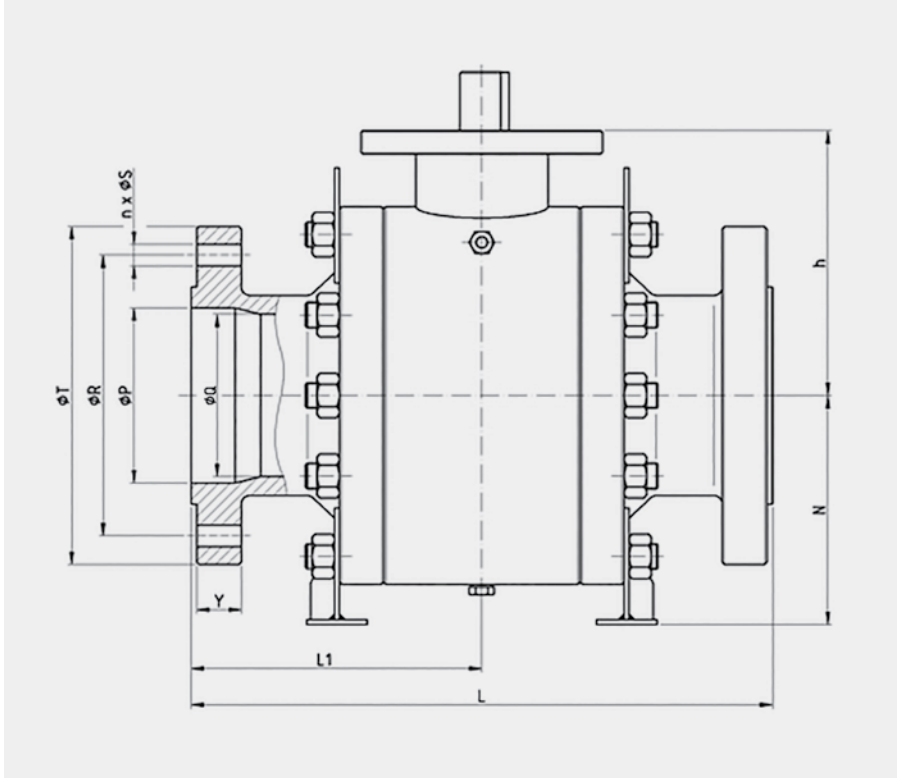

(*) Dimensions of diameters of drills ISO 5211 refer to table from page 60.

Pressure - Temperature

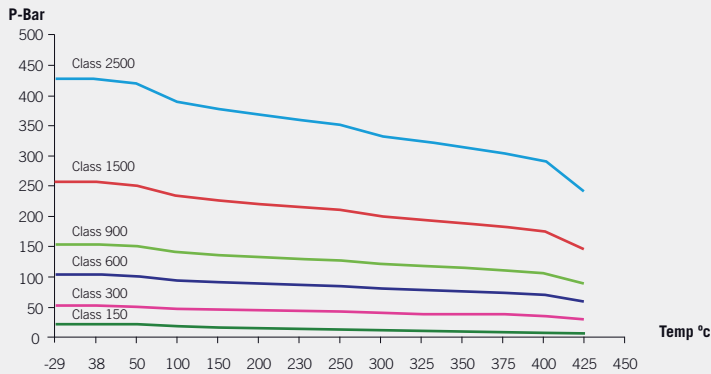

Fig. 7015 (Class 150)

DN	øP	øQ	L	L1	øR	n x øS	øT	Y	h	N	ISO 5211	H	øA	J	K	WEIGHT	TORQUE	Kv
3" x 2"	76	49	203	101,5	152.4	4 x 19	190	18	125	100	F10	36,5	20	8	22,5	66	41	190
4" x 3"	102	76	229	114,5	190.5	8 x 19	230	22	156,5	133,5	F12	37,5	26	10	30	75	97	567
6" x 4"	152	102	394	197	241.3	8 x 22	280	24	175	167	F12	54	30	10	34	115	170	815
8" x 6"	203	152	457	228,5	298.5	8 x 22.2	345	27	269	277	F16	71	39,9	14	48,9	205	457	2.021
10" x 8"	254	203	533	266,5	362	12 x 25.4	405	29	325	325	F25	77	49,9	14	58,4	375	845	4.205
12" x 10"	305	254	610	305	431.8	12 x 25.4	485	30	362	319	F25	84,5	59,9	16	67	565	1.396	7.348
14" x 12"	337	305	686	343	476.3	12 x 28.5	535	33	423	399	F25	104	69,9	18	78	825	2.836	10.120
16" x 14"	387	337	762	381	538.8	16 x 28.5	595	35	455	439	F30	119	79,9	22	87,9	1.250	3.411	12.000
18" x 16"	438	387	864	432	577.9	16 x 31.8	635	38	490	472	F30	134	84,9	22	94,9	1.820	4.501	17.269
20" x 18"	488	438	914	457	635	20 x 31.8	700	41	542	596	F30	147,5	99,9	28	111,9	2.450	6.543	18.647
24" x 20"	589	488	1.067	533,5	749.3	20 x 34.9	815	46	577	610	F30	147,5	99,9	28	111,9	2.790	8.238	27.010
30" x 24"	735	589	1.295	647,5	857	28 x 35	985	73	599	692	F40	152	120	32	134	5.530	20.908	32.150

(**) Dimensions in mm and weight in kg.
(**) Weights and dimensions can be changed without notice.
(1) Bigger sizes available under customers request.

Fig. 7030 (Class 300)

DN	øP	øS	L	L1	øR	n x øS	øT	Y	h	N	ISO 5211	H	øA	J	K	WEIGHT	TORQUE	Kv
3" x 2"	76	49	283	141,5	168,3	8 x 22,2	210	27	125	95	F10	36,5	20	8	22,5	65	83	190
4" x 3"	102	76	305	152,5	200	8 x 22,2	255	30	156,5	133,5	F12	37,5	26	10	30	85	208	567
6" x 4"	152	102	403	201,5	269,9	12 x 22,2	320	35	175	167	F12	54	30	10	34	135	380	815
8" x 6"	203	152	502	251	330,2	12 x 25,4	380	40	269	277	F16	71	39,9	14	48,9	225	1.089	2.021
10" x 8"	254	203	568	284	387,4	16 x 28,5	445	46	325	293	F25	77	49,9	14	58,4	385	2.060	4.205
12" x 10"	305	254	648	324	450,8	16 x 31,8	520	49	362	335	F25	84,5	59,9	16	67	650	3.497	7.348
14" x 12"	337	305	762	381	514,4	20 x 31,8	585	52	423	399	F25	104	69,9	18	78	995	7.256	10.120
16" x 14"	387	337	838	419	571,5	20 x 34,9	650	56	455	439	F30	119	79,9	22	87,9	1.460	8.579	12.000
18" x 16"	438	387	914	457	628,6	24 x 34,9	710	59	490	472	F30	134	84,9	22	94,9	1.925	11.344	17.269
20" x 18"	488	438	991	495,5	685,8	24 x 34,9	775	62	542	596	F30	147,5	99,9	28	111,9	2.450	16.348	18.647
24" x 20"	589	488	1.143	571,5	812,8	24 x 41,3	915	68	577	610	F30	147,5	99,9	28	111,9	3.250	20.945	27.010
30" x 24"	735	589	1.397	698,5	857	28 x 48	1.092	90	599	673	F40	152	120	32	134	5.900	44.489	32.150

Fig. 7060 (Class 600)

DN	øP	øS	L	L1	øR	n x øS	øT	Y	h	N	ISO 5211	H	øA	J	K	WEIGHT	TORQUE	Kv
3" x 2"	76	49	356	178	168,3	8 x 22,2	210	32	125	100	F10	36,5	20	8	22,5	72	153	190
4" x 3"	102	76	432	216	215,9	8 x 25,4	275	38	156,5	138,5	F12	37,5	26	10	30	93	355	567
6" x 4"	152	102	559	279,5	292,1	12 x 28,5	355	48	175	164	F12	54	30	10	34	169	716	815
8" x 6"	203	152	660	330	349,2	12 x 31,8	420	56	268,5	277,5	F16	71	44,9	14	51,4	301	2.211	2.021
10" x 8"	254	203	787	393,5	431,8	16 x 34,9	510	64	325	296	F25	77	54,9	14	61,4	555	4.131	4.205
12" x 10"	305	254	838	419	489	20 x 34,9	560	67	362	365	F25	84,5	59,9	16	67	829	6.891	7.348
14" x 12"	337	305	889	444,5	527	20 x 38,1	605	70	423	418	F25	104	69,9	18	78	1.426	13.065	10.120
16" x 14"	387	337	991	495,5	603,2	20 x 41,3	685	76	455	450	F30	119	79,9	22	87,9	1.751	15.373	12.000
18" x 16"	438	387	1.092	546	654	20 x 44,5	745	83	490	504	F30	134	84,9	22	94,9	2.625	20.339	17.269
20" x 18"	488	438	1.194	597	723,9	24 x 44,5	815	89	542	567,5	F30	147,5	99,9	28	111,9	3.111	29.257	18.647
24" x 20"	589	488	1.397	698,5	838,2	24 x 50,8	940	102	577	581	F35	147,5	99,9	28	111,9	4.250	37.645	27.010
30" x 24"	735	589	1.651	825,5	857	28 x 54	1.130	108	599	694	F40	157,5	119,8	32	133,6	7.125	76.800	32.150

Fig. 7090 (Class 900)

DN	øP	øS	L	L1	øR	n x øS	øT	Y	h	N	ISO 5211	H	øA	J	K	WEIGHT	TORQUE	Kv
3" x 2"	77	51	381	190,5	190,5	8 x 25,4	240	38,1	120	101	F14	46	29	8	32,5	62	518	190
4" x 3"	102	77	457	228,5	235	8 x 31,8	290	44,5	153	124	F16	50	39,9	10	44,5	105	1.193	567
6" x 4"	152	102	610	305	317,5	12 x 31,8	380	55,6	170	151	F25	56	39,9	10	44,5	201	1.843	815
8" x 6"	203	152	737	368,5	393,7	12 x 38,1	470	63,5	214	380	F25	63	44,9	14	51,4	436	3.339	2.021
10" x 8"	254	203	838	419	469,9	16 x 38,1	545	69,9	258	428	F25	87	65	16	74,5	735	8.596	4.205
12" x 10"	305	254	965	482,5	533,4	20 x 38,1	610	79,4	303	489	F25	90	75	20	81	1.200	12.271	7.348
14" x 12"	324	305	1.029	514,5	558,8	20 x 41,3	640	85,8	348	525	F25	99	85	22	95	1.795	19.382	10.120

Fig. 7050 (Class 1500)

DN	øP	øS	L	L1	øR	n x øS	øT	Y	h	N	ISO 5211	H	øA	J	K	WEIGHT	TORQUE	Kv
3" x 2"	77	51	473	236,5	203,2	8 x 31,8	265	47,7	129	107	F14	46	29	8	32,5	80	866	190
4" x 3"	102	77	549	274,5	241,3	8 x 34,9	310	54	156	137	F25	55	39,9	10	44,5	156	2.253	567
6" x 4"	146	102	711	355,5	317,5	12 x 38,1	395	82,6	193	168	F25	56	39,9	10	44,5	325	3.105	815
8" x 6"	194	146	841	420,5	393,7	12 x 44,5	485	92,1	242	395	F25	95	60	18	64	603	5.428	2.021
10" x 8"	241	194	1.000	500	482,6	12 x 50,8	585	108	292	445	F25	119	75	18	82,9	950	15.333	4.205

(*) Dimensions in mm and weight in kg.
 (***) Weights and dimensions can be changed without notice.
 (1) Bigger sizes available under customers request.

| BALL VALVES |

3-PIECE FORGED TRUNNION MOUNTED

2" - 42" | Class 150 - Class 2500

A trunnion ball valve has additional mechanical anchoring of the ball at the top and the bottom, suitable for larger and higher pressure valves.

The JC trunnion mounted ball valves are suitable to stand the harsh service conditions often presented in the hydrocarbon industry and in the gas storage and transportation field. In general, they are recommended for tight shut-off in high pressure and double block and bleed applications.

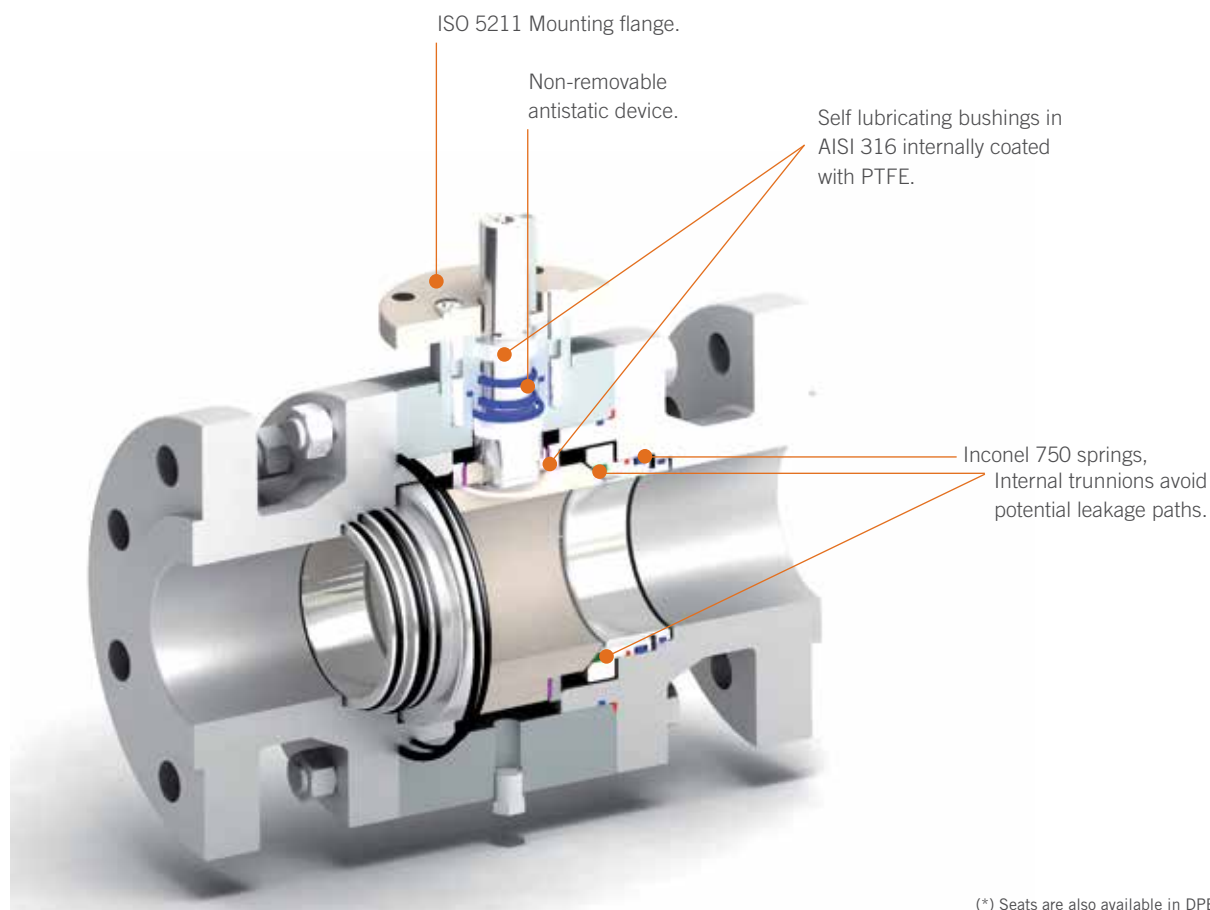

(*) Seats are also available in DPE (Double Piston Effect) and PMSS (Primary Metal, Secondary Soft).

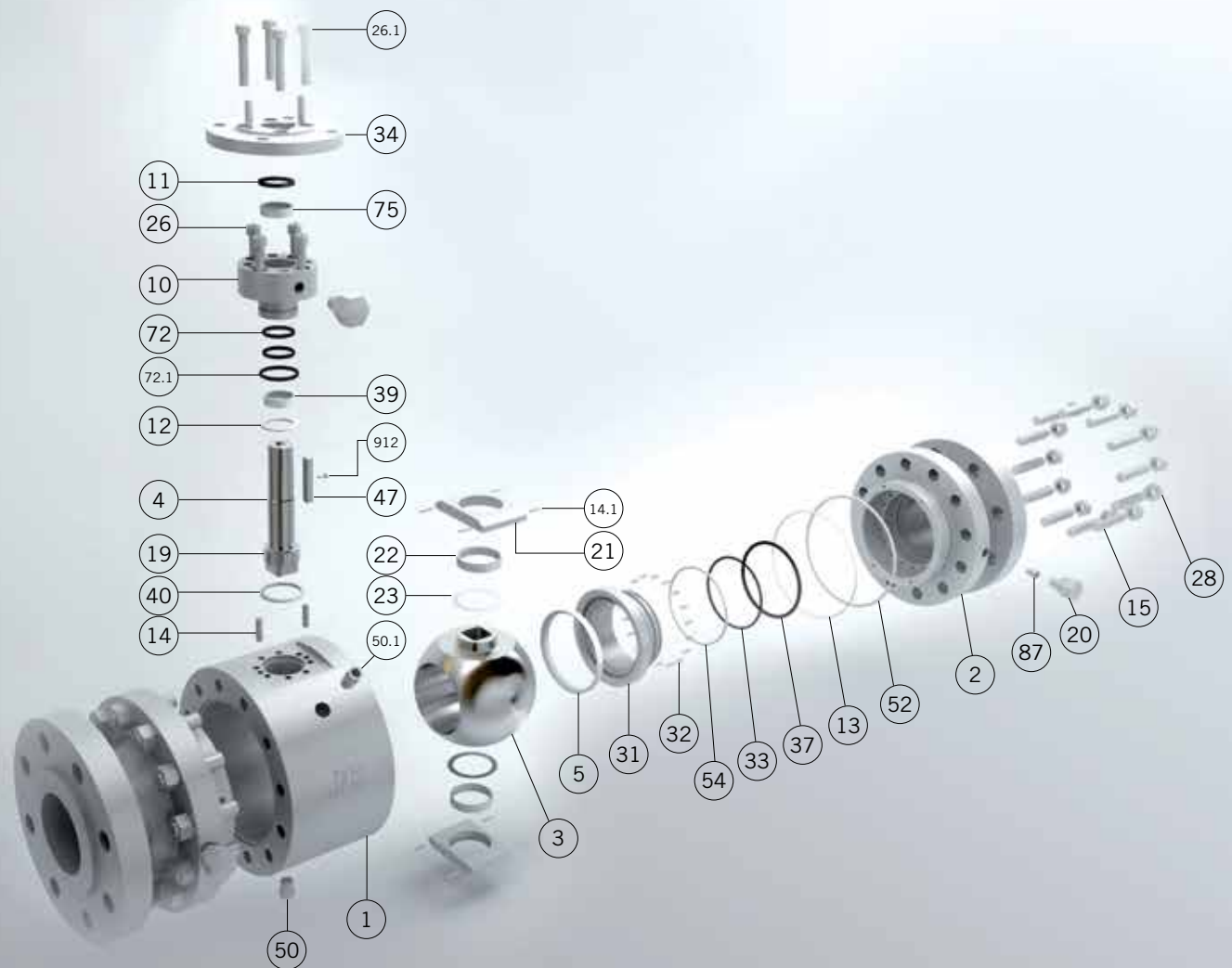

Materials

SERIES 6000 & 7000

Item	Description	AIT	LIT	IIT
1	Body	A 105N	A 350 Gr. LF2 Class. 1	A182 F316
2	Body Connector	A 105N	A 350 Gr. LF2 Class. 1	A182 F316
3	Ball		A 182 F316 or A351 Gr. CF8M / A105+ENP	
4	Stem		A 479 Tp.316	
5	Seat Ring		RPTFE, PEEK, DEVLON	
10	Gland	A 105N	A 350 Gr. LF2 Class-1	A 479 Tp.316
11	Gland Packing		Graphite	
12	Stem Thrust Seal		25% G.F. + PTFE	
13	Body Connector Seal		Graphite	
14 / 14.1	Pin	Carbon St.	Carbon Steel	Stainless Steel
15	Stud	A 193 Gr. B7M Zinc dichromate	A 320 Gr. L7M	A 193 Gr. B8M
19	Antistatic Device		Stainless St.	
20	Sealant Injector	Carbon Steel	Carbon Steel	Stainless Steel
21	Ball Trunnion		A 479 Tp.316	
22	Trunnion Bearing		AISI 316 with inside in PTFE	
23	Bearing		PTFE	
26 / 26.1	Bolt	A 193 Gr. B7M Zinc dichromate	A 320 Gr. L7M	A 193 Gr. B8M
28	Nut	A 194 Gr. 2HM Zinc dichromate	A 194 Gr. 7M	A 194 Gr. 8M
31	Seat Carrier		A 479 Tp.316 / A182 F316	
32	Spring		Inconel - 750	
33	"O" Ring		FKM	
34	Mounting Flange	A 105N	A 350 Gr. LF2 Class-1	A 479 Tp.316
37	"O" Ring		FKM	
39	Stem Bushing		AISI 316 with inside in PTFE	
40	Gasket		Graphite	
47	Key	Carbon Steel	Carbon Steel	Stainless St.
50	Drain Plug	A 105	A 350 Gr. LF2 Class-1	AISI 316
50.1	Relieve Plug	A 105	A 350 Gr. LF2 Class-1	AISI 316
52	"O" Ring		FKM	
54	Seat Carrier Seal		Graphite	
72 / 72.1	"O" Ring		FKM	
75	Stem Bushing		AISI 316 with inside in PTFE	
87	Check Valve		Stainless St.	
912	Bolt		DIN 912 A2	

FORGED BALL VALVES 6015 / 6030 / 6060 / 6090 / 6050 / 6042

Full Bore

Class 150.
From 2" to 42" (1)

Class 300.
From 2" to 42" (1)

Class 600.
From 2" to 24"

Class 900.
From 2" to 24"

Class 1500.
From 2" to 12"

Class 2500.
From 2" to 8"

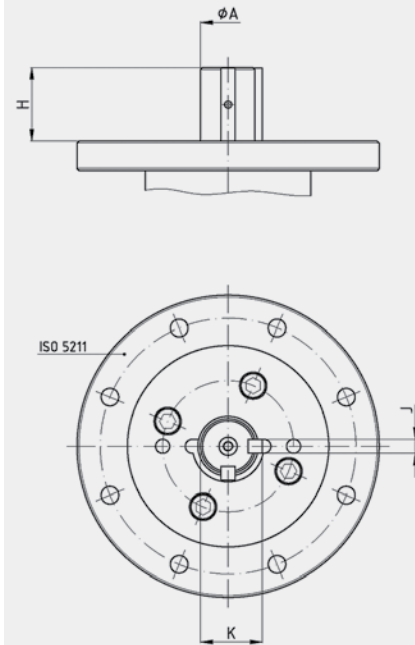
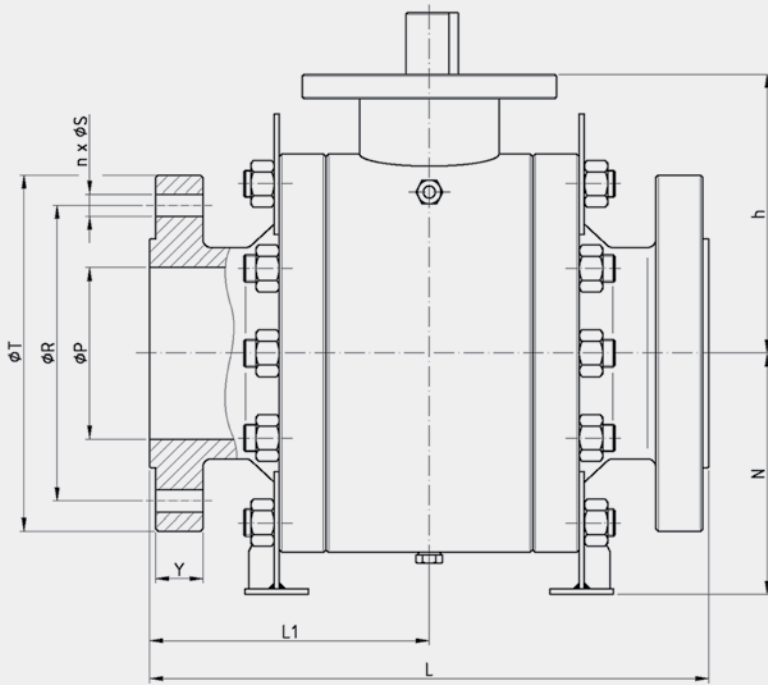

(*) Dimensions of diameters of drills ISO 5211 refer to table on page 60.

Pressure - Temperature

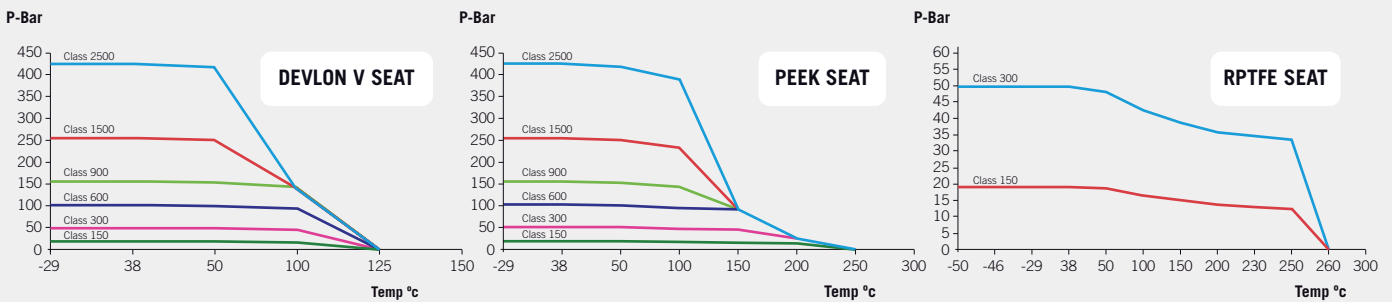

Fig. 6015 (Class 150)

DN	φP	L	L1	φR	n x φS	φT	Y	h	N	ISO 5211	H	φA	J	K	WEIGHT	TORQUE	Kv
2"	49	178	89	120.7	4 x 19	150	14	125	100	F10	36,5	20	8	22,5	24	76	366
3"	76	203	101,5	152.4	4 x 19	190	18	156,5	133,5	F12	37,5	26	10	30	47	189	938
4"	102	229	114,5	190.5	8 x 19	230	22	175	167	F12	54	30	10	34	86	289	1.465
6"	152	394	197	241.3	8 x 22	280	24	269	277	F16	71	39,9	14	48,9	191	581	3.297
8"	203	457	228,5	298.5	8 x 22.2	345	27	325	325	F25	77	49,9	14	58,4	357	916	5.861
10"	254	533	266,5	362	12 x 25.4	405	29	362	319	F25	84,5	59,9	16	67	529	1.230	9.454
12"	305	610	305	431.8	12 x 25.4	485	30	423	399	F25	104	69,9	18	78	794	1.528	13.631
14"	337	686	343	476.3	12 x 28.5	535	33	455	439	F30	119	79,9	22	87,9	1.120	2.391	16.641
16"	387	762	381	539.8	16 x 28.5	595	35	490	472	F30	134	84,9	22	94,9	1.473	3.154	23.554
18"	438	864	432	577.9	16 x 31.8	635	38	542	596	F30	147,5	99,9	28	111,9	1.860	4.115	29.672
20"	488	914	457	635	20 x 31.8	700	41	577	610	F30	147,5	99,9	28	111,9	2.589	5.225	36.633
24"	589	1.067	533,5	749.3	20 x 34.9	815	46	599	692	F40	152	120	32	134	4.302	10.248	52.751

(**) Dimensions in mm and weight in kg.
(**) Weights and dimensions can be changed without notice.
(1) Bigger sizes available under customers request.

Fig. 6030 (Class 300)

DN	øP	L	L1	øR	n x øS	øT	Y	h	N	ISO 5211	H	øA	J	K	WEIGHT	TORQUE	Kv
2"	49	216	108	127	8 x 19	165	21	125	95	F10	36,5	20	8	22,5	28	95	366
3"	76	283	141,5	168,3	8 x 22,2	210	27	156,5	133,5	F12	37,5	26	10	30	61	259	938
4"	102	305	152,5	200	8 x 22,2	255	30	175	167	F12	54	30	10	34	100	384	1.465
6"	152	403	201,5	269,9	12 x 22,2	320	35	269	277	F16	71	39,9	14	48,9	217	871	3.297
8"	203	502	251	330,2	12 x 25,4	380	40	325	293	F25	77	49,9	14	58,4	387	1.344	5.861
10"	254	568	284	387,4	16 x 28,5	445	46	362	335	F25	84,5	59,9	16	67	610	1.842	9.454
12"	305	648	324	450,8	16 x 31,8	520	49	423	399	F25	104	69,9	18	78	882	2.216	13.631
14"	337	762	381	514,4	20 x 31,8	585	52	455	439	F30	119	79,9	22	87,9	1.296	3.584	16.641
16"	387	838	419	571,5	20 x 34,9	650	56	490	472	F30	134	84,9	22	94,9	1.687	4.729	23.554
18"	438	914	457	628,6	24 x 34,9	710	59	542	596	F30	147,5	99,9	28	111,9	2.057	6.716	29.672
20"	488	991	495,5	685,8	24 x 34,9	775	62	577	610	F30	147,5	99,9	28	111,9	2.872	9.050	36.633
24"	589	1.143	571,5	812,8	24 x 41,3	915	68	599	673	F40	152	120	32	134	5.525	16.123	52.751

Fig. 6060 (Class 600)

DN	øP	L	L1	øR	n x øS	øT	Y	h	N	ISO 5211	H	øA	J	K	WEIGHT	TORQUE	Kv
2"	49	292	146	127	8 x 19	165	25	125	100	F10	36,5	20	8	22,5	33	125	366
3"	76	356	178	168,3	8 x 22,2	210	32	156,5	138,5	F12	37,5	26	10	30	75	373	938
4"	102	432	216	213,9	8 x 25,4	275	38	175	164	F12	54	30	10	34	136	538	1.465
6"	152	559	279,5	292,1	12 x 28,5	355	48	268,5	277,5	F16	71	44,9	14	51,4	300	1.343	3.297
8"	203	660	330	349,2	12 x 31,8	420	56	325	296	F25	77	54,9	14	61,4	561	2.040	5.861
10"	254	787	393,5	431,8	16 x 34,9	510	64	362	365	F25	84,5	59,9	16	67	828	2.836	9.454
12"	305	838	419	489	20 x 34,9	560	67	423	418	F25	104	69,9	18	78	1.238	3.334	13.631
14"	337	889	444,5	527	20 x 38,1	605	70	455	450	F30	119	79,9	22	87,9	1.532	5.523	16.641
16"	387	991	495,5	603,2	20 x 41,3	685	76	490	504	F30	134	84,9	22	94,9	2.137	7.289	23.554
18"	438	1.092	546	654	20 x 44,5	745	83	542	567,5	F30	147,5	99,9	28	111,9	2.595	10.941	29.672
20"	488	1.194	597	723,9	24 x 44,5	815	89	577	581	F35	147,5	99,9	28	111,9	3.454	15.263	36.633
24"	589	1.397	698,5	838,2	24 x 50,8	940	102	599	694	F40	157,5	119,8	32	133,6	6.250	25.666	52.751

Fig. 6090 (Class 900)

DN	øP	L	L1	øR	n x øS	øT	Y	h	N	ISO 5211	H	øA	J	K	WEIGHT	TORQUE	Kv
2"	51	368	184	165,1	8 x 25,4	215	38,1	120	101	F14	46	29	8	32,5	52	212	366
3"	77	381	190,5	190,5	8 x 25,4	240	38,1	153	124	F16	50	39,9	10	44,5	80	585	938
4"	102	457	228,5	235	8 x 31,8	290	44,5	170	151	F25	56	39,9	10	44,5	170	830	1.465
6"	152	610	305	317,5	12 x 31,8	380	55,6	214	380	F25	63	44,9	14	51,4	390	2.179	3.297
8"	203	737	368,5	393,7	12 x 38,1	470	63,5	258	428	F25	87	65	16	74,5	640	3.283	5.861
10"	254	838	419	469,9	16 x 38,1	545	69,9	303	489	F25	90	75	20	81	1.070	4.656	9.454
12"	305	965	482,5	533,4	20 x 38,1	610	79,4	348	525	F25	99	85	22	95	1.610	5.343	13.631
14"	324	1.029	514,5	558,8	20 x 41,3	640	85,8	381	545	F30	125	85	22	95	1.760	8.953	16.641
16"	375	1.130	565	616	20 x 44,5	705	88,9	418	580	F30	125	88	24	100	2.240	11.818	23.554
18"	425	1.219	609,5	685,8	20 x 50,8	785	101,6	464	630	F35	130	120	32	136	3.000	18.318	29.672
20"	473	1.321	660,5	749,3	20 x 54	855	108	507	672	F35	130	120	32	136	4.360	25.770	36.633
24"	571	1.549	774,5	901,7	20 x 66,7	1.040	139,7	596	760	F35	130	148	32	164	7.050	42.250	52.751

Fig. 6050 (Class 1500)

DN	øP	L ⁽²⁾	L1	øR	n x øS	øT	Y	h	N	ISO 5211	H	øA	J	K	WEIGHT	TORQUE	Kv
2"	51	371	185,5	165,1	8 x 25,4	215	38,1	129	107	F14	46	29	8	32,5	55	331	366
3"	77	473	236,5	203,2	8 x 31,8	265	47,7	156	137	F25	55	39,9	10	44,5	105	858	938
4"	102	549	274,5	241,3	8 x 34,9	310	54	193	168	F25	56	39,9	10	44,5	205	1.324	1.465
6"	146	711	355,5	317,5	12 x 38,1	395	82,6	242	395	F25	95	60	18	64	525	3.367	3.297
8"	194	841	420,5	393,7	12 x 44,5	485	92,1	292	445	F25	119	75	18	82,9	890	5.364	5.861
10"	241	1.000	500	482,6	12 x 50,8	585	108	336	505	F25	133	85	22	95	1.560	7.152	9.454
12"	289	1.146	573	571,5	16 x 54	675	123,9	399	565	F25	140	85	24	100	2.355	8.227	13.631

Fig. 6042 (Class 2500)

DN	øP	L ⁽²⁾	L1	øR	n x øS	øT	Y	h	N	ISO 5211	H	øA	J	K	WEIGHT	TORQUE	Kv
2"	44,5	454	227	171,4	8 x 28,6	235	50,9	150	125	F16	39	33	10	38	110	554	366
3"	64	584	292	228,6	8 x 34,9	305	66,7	182	151	F16	39	38	10	43	215	1.530	938
4"	89	683	341,5	273,0	8 x 41,3	355	76,2	214	187	F25	66	46	14	53	385	2.025	1.465
6"	133	927	463,5	368,3	8 x 54	485	108	282	430	F25	78,5	58	18	67	840	5.428	3.297
8"	181	1.038	519	438,2	12 x 54	550	127	356	495	F25	105,5	78	20	88	1.435	9.809	5.861

(*) Dimensions in mm and weight in kg.

(**) Weights and dimensions can be changed without notice.

(1) Bigger sizes available under customers request. (2) With RTS Flanges.

FORGED BALL VALVES 7015 / 7030 / 7060 / 7090 / 7050 / 7042

Reduced Bore

Class 150.
From 3" to 42" (1)

Class 300.
From 3" to 42" (1)

Class 600.
From 3" to 30"

Class 900.
From 3" to 30"

Class 1500.
From 3" to 14"

Class 2500.
From 3" to 10"

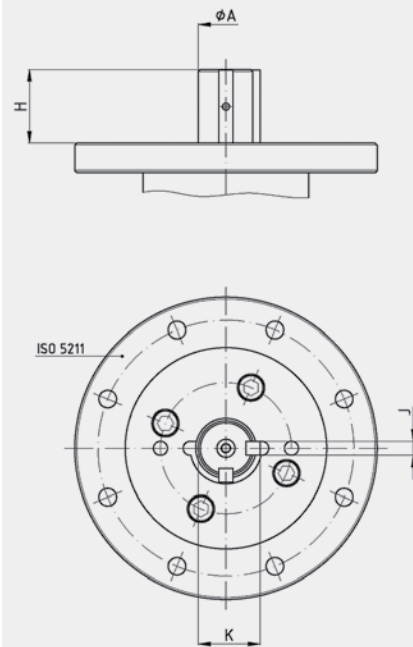
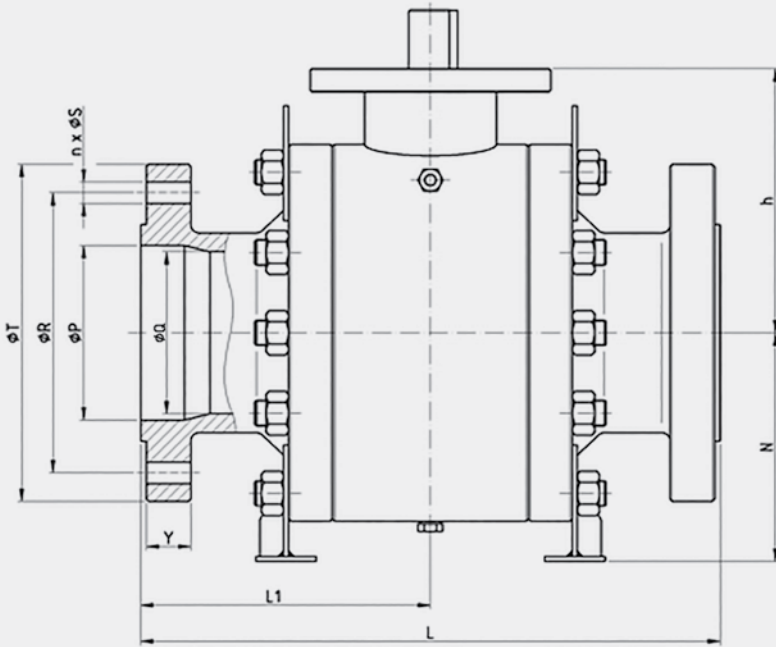

(*) Dimensions of diameters of drills ISO 5211 refer to table from page 60.

Pressure - Temperature

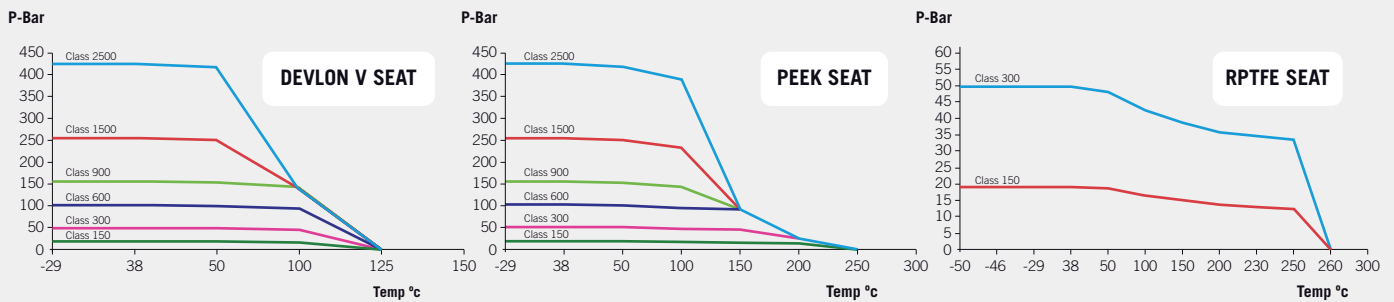

Fig. 7015 (Class 150)

DN	øP	øQ	L	L1	øR	n x øS	øT	Y	h	N	ISO 5211	H	øA	J	K	WEIGHT	TORQUE	Kv
3" x 2"	76	49	203	101,5	152,4	4 x 19	190	18	125	100	F10	36,5	20	8	22,5	66	76	190
4" x 3"	102	76	229	114,5	190,5	8 x 19	230	22	156,5	133,5	F12	37,5	26	10	30	75	189	567
6" x 4"	152	102	394	197	241,3	8 x 22	280	24	175	167	F12	54	30	10	34	115	289	815
8" x 6"	203	152	457	228,5	298,5	8 x 22,2	345	27	269	277	F16	71	39,9	14	48,9	205	581	2.021
10" x 8"	254	203	533	266,5	362	12 x 25,4	405	29	325	325	F25	77	49,9	14	58,4	375	916	4.205
12" x 10"	305	254	610	305	431,8	12 x 25,4	485	30	362	319	F25	84,5	59,9	16	67	565	1.230	7.348
14" x 12"	337	305	686	343	476,3	12 x 28,5	535	33	423	399	F25	104	69,9	18	78	825	1.528	10.120
16" x 14"	387	337	762	381	538,8	16 x 28,5	595	35	455	439	F30	119	79,9	22	87,9	1.250	2.391	12.000
18" x 16"	438	387	864	432	577,9	16 x 31,8	635	38	490	472	F30	134	84,9	22	94,9	1.820	3.154	17.269
20" x 18"	488	438	914	457	635	20 x 31,8	700	41	542	596	F30	147,5	99,9	28	111,9	2.450	4.115	18.647
24" x 20"	589	488	1.067	533,5	749,3	20 x 34,9	815	46	577	610	F30	147,5	99,9	28	111,9	2.790	5.225	27.010
30" x 24"	735	589	1.295	647,5	857	28 x 35	985	73	599	692	F40	152	120	32	134	5.530	10.248	32.150

(**) Dimensions in mm and weight in kg.
(**) Weights and dimensions can be changed without notice.
(1) Bigger sizes available under customers request.

Fig. 7030 (Class 300)

DN	øP	øS	L	L1	øR	n x øS	øT	Y	h	N	ISO 5211	H	øA	J	K	WEIGHT	TORQUE	Kv
3" x 2"	76	49	283	141,5	168.3	8 x 22.2	210	27	125	95	F10	36,5	20	8	22,5	65	95	190
4" x 3"	102	76	305	152,5	200	8 x 22.2	255	30	156,5	133,5	F12	37,5	26	10	30	85	259	567
6" x 4"	152	102	403	201,5	269.9	12 x 22.2	320	35	175	167	F12	54	30	10	34	135	384	815
8" x 6"	203	152	502	251	330.2	12 x 25.4	380	40	269	277	F16	71	39,9	14	48,9	225	871	2.021
10" x 8"	254	203	568	284	387.4	16 x 28.5	445	46	325	293	F25	77	49,9	14	58,4	385	1.344	4.205
12" x 10"	305	254	648	324	450.8	16 x 31.8	520	49	362	335	F25	84,5	59,9	16	67	650	1.842	7.348
14" x 12"	337	305	762	381	514.4	20 x 31.8	585	52	423	399	F25	104	69,9	18	78	995	2.216	10.120
16" x 14"	387	337	838	419	571.5	20 x 34.9	650	56	455	439	F30	119	79,9	22	87,9	1.460	3.584	12.000
18" x 16"	438	387	914	457	628.6	24 x 34.9	710	59	490	472	F30	134	84,9	22	94,9	1.925	4.729	17.269
20" x 18"	488	438	991	495,5	685.8	24 x 34.9	775	62	542	596	F30	147,5	99,9	28	111,9	2.450	6.716	18.647
24" x 20"	589	488	1.143	571,5	812.8	24 x 41.3	915	68	577	610	F30	147,5	99,9	28	111,9	3.250	9.050	27.010
30" x 24"	735	589	1.397	698,5	857	28 x 48	1.092	90	599	673	F40	152	120	32	134	5.900	16.123	32.150

Fig. 7060 (Class 600)

DN	øP	øS	L	L1	øR	n x øS	øT	Y	h	N	ISO 5211	H	øA	J	K	WEIGHT	TORQUE	Kv
3" x 2"	76	49	356	178	168.3	8 x 22.2	210	32	125	100	F10	36,5	20	8	22,5	72	125	190
4" x 3"	102	76	432	216	215.9	8 x 25.4	275	38	156,5	138,5	F12	37,5	26	10	30	93	373	567
6" x 4"	152	102	559	279,5	292.1	12 x 28.5	355	48	175	164	F12	54	30	10	34	169	538	815
8" x 6"	203	152	660	330	349.2	12 x 31.8	420	56	268,5	277,5	F16	71	44,9	14	51,4	301	1.343	2.021
10" x 8"	254	203	787	393,5	431.8	16 x 34.9	510	64	325	296	F25	77	54,9	14	61,4	555	2.040	4.205
12" x 10"	305	254	838	419	489	20 x 34.9	560	67	362	365	F25	84,5	59,9	16	67	829	2.836	7.348
14" x 12"	337	305	889	444,5	527	20 x 38.1	605	70	423	418	F25	104	69,9	18	78	1.426	3.334	10.120
16" x 14"	387	337	991	495,5	603.2	20 x 41.3	685	76	455	450	F30	119	79,9	22	87,9	1.751	5.523	12.000
18" x 16"	438	387	1.092	546	654	20 x 44.5	745	83	490	504	F30	134	84,9	22	94,9	2.625	7.289	17.269
20" x 18"	488	438	1.194	597	723.9	24 x 44.5	815	89	542	567,5	F30	147,5	99,9	28	111,9	3.111	10.941	18.647
24" x 20"	589	488	1.397	698,5	838.2	24 x 50.8	940	102	577	581	F35	147,5	99,9	28	111,9	4.250	15.263	27.010
30" x 24"	735	589	1.651	825,5	857	28 x 54	1.130	108	599	694	F40	157,5	119,8	32	133,6	7.125	25.666	32.150

Fig. 7090 (Class 900)

DN	øP	øS	L	L1	øR	n x øS	øT	Y	h	N	ISO 5211	H	øA	J	K	WEIGHT	TORQUE	Kv
3" x 2"	77	51	381	190,5	190,5	8 x 25.4	240	38,1	120	101	F14	46	29	8	32,5	62	212	190
4" x 3"	102	77	457	228,5	235	8 x 31.8	290	44,5	153	124	F16	50	39,9	10	44,5	105	585	567
6" x 4"	152	102	610	305	317,5	12 x 31.8	380	55,6	170	151	F25	56	39,9	10	44,5	201	830	815
8" x 6"	203	152	737	368,5	393,7	12 x 38.1	470	63,5	214	380	F25	63	44,9	14	51,4	436	2.179	2.021
10" x 8"	254	203	838	419	469,9	16 x 38.1	545	69,9	258	428	F25	87	65	16	74,5	735	3.283	4.205
12" x 10"	305	254	965	482,5	533,4	20 x 38.1	610	79,4	303	489	F25	90	75	20	81	1.200	4.656	7.348
14" x 12"	324	305	1.029	514,5	558,8	20 x 41.3	640	85,8	348	525	F25	99	85	22	95	1.795	5.343	10.120
16" x 14"	375	324	1.130	565	616	20 x 44.5	705	88,9	381	545	F30	125	85	22	95	2.105	8.953	12.000
18" x 16"	425	375	1.219	609,5	685,8	20 x 50.8	785	101,6	418	580	F30	125	88	24	100	2.720	11.818	17.269
20" x 18"	473	425	1.321	660,5	749,3	20 x 54	855	108	464	630	F35	130	120	32	136	4.050	18.318	18.647
24" x 20"	571	473	1.549	774,5	901,7	20 x 66.7	1.040	139,7	507	672	F35	130	120	32	136	4.650	25.770	27.010
30" x 24"	712	571	1.803	901,5	857,0	20 x 72	1.232	142,0	596	760	F35	130	148	32	164	7.950	42.250	32.150

Fig. 7050 (Class 1500)

DN	øP	øS	L	L1	øR	n x øS	øT	Y	h	N	ISO 5211	H	øA	J	K	WEIGHT	TORQUE	Kv
3" x 2"	77	51	473	236,5	203,2	8 x 31.8	265	47,7	129	107	F14	46	29	8	32,5	80	331	190
4" x 3"	102	77	549	274,5	241,3	8 x 34.9	310	54	156	137	F25	55	39,9	10	44,5	156	858	567
6" x 4"	146	102	711	355,5	317,5	12 x 38.1	395	82,6	193	168	F25	56	39,9	10	44,5	325	1.324	815
8" x 6"	194	146	841	420,5	393,7	12 x 44.5	485	92,1	242	395	F25	95	60	18	64	603	3.367	2.021
10" x 8"	241	194	1.000	500	482,6	12 x 50.8	585	108	292	445	F25	119	75	18	82,9	950	5.364	4.205
12" x 10"	289	241	1.146	573	571,5	16 x 54	675	123,9	336	505	F25	133	85	22	95	1.825	7.152	7.348
14" x 12"	318	289	1.276	638	635	16 x 60	750	133,4	399	565	F25	140	85	24	100	2.750	8.227	10.120

Fig. 7042 (Class 2500)

DN	øP	øS	L	L1	øR	n x øS	øT	Y	h	N	ISO 5211	H	øA	J	K	WEIGHT	TORQUE	Kv
3" x 2"	64	44,5	584	292	228,6	8 x 34.9	305	66,7	150	125	F16	39	33	10	38	140	554	190
4" x 3"	89	64	683	341,5	273,0	8 x 41.3	355	76,2	182	151	F16	39	38	10	43	250	1.530	567
6" x 4"	133	89	927	463,5	368,3	8 x 54	485	108	214	187	F25	66	46	14	53	520	2.025	815
8" x 6"	181	133	1.038	519	438,2	12 x 54	550	127	282	430	F25	78,5	58	18	67	1.000	5.428	2.021
10" x 8"	226	181	1.292	646	539,8	12 x 66	675	165	356	495	F25	105,5	78	20	88	1.850	9.809	4.205

(*) Dimensions in mm and weight in kg.
 (**) Weights and dimensions can be changed without notice.
 (1) Bigger sizes available under customers request.

| BALL VALVES |

2-PIECE CAST TRUNNION MOUNTED CAST TRUNNION

2" - 16" | Class 150 - Class 600

Materials CAST TRUNNION

Item	Description	AIT	IIT
1	Body	A 216 Gr. WCB (C ≤ 0.25%)	A 351 Gr. CF8M
2	Body connector	A 216 Gr. WCB (C ≤ 0.25%)	A 351 Gr. CF8M
3	Ball	A 351 Gr. CF8M	
4	Stem	A 479 Tp.316	
5	Seat ring	RPTFE, PTFE, DEVLON	
7	Gland nut	Zinc Plated Carbon Steel	AISI-303
8	Disk spring / Spring	Carbon St. *	E. N.P. Carbon St. *
9	Stop plate	Carbon St.	AISI-304
10	Gland ring	AISI-303	AISI-316
10.1	Gland	AISI-303	AISI-316
11	Gland packing	Graphite	
12	Stem thrust seal	25% G.F. PTFE	
13	Body connector seal	AISI-316L + Graphite	
14	Stop pin	Carbon St.	Stainless St.
15	Stud	A 193 Gr. B7M Zinc dichromate	A 193 Gr. B8M **
18	Thrust washer	25% G.F. PTFE	
19	Antistatic device	Stainless St.	
21 / 21a	Ball trunnion	A 351 Gr. CF8M	
22 / 22a	Trunnion bearing	AISI-316 + PTFE	
23	Bearing	PTFE	
26	Bolt	DIN 912 8.8 Zinc Plated	DIN 912 A2
28	Nut	A 194 Gr. 2HM Zinc dichromate	A 194 Gr. 8M **
31	Seat Carrier	A 351 Gr. CF8M	
32	Spring	Inconel - 750	
33	O' Ring	FKM -- Note 1 --	
35	Spring carrier	A 351 Gr. CF8M	
37	O' Ring	FKM -- Note 1 --	
39	Stem bushing	25% G.F. PTFE	
39.1	Stem bushing	AISI-316 + PTFE -- Note 2 --	
41	Spacer	Carbon St.	Stainless St.
43	Key	AISI-316	
46	Locking washer	AISI-304	
47	Key	Carbon St.	
50	Drain plug	A 105	AISI-316
50.1	Vent plug	A 105	AISI-316
52	O' Ring	FKM -- Note 2 --	
54	Seat carrier seal	Graphite	
58	Spring protection	Carbon St.	Stainless St.
72	O' Ring	FKM -- Note 1 --	
75	Stem bushing	AISI-316 + PTFE -- Note 2 --	
89	Identification plate	Stainless St.	
471	Retainer	Carbon St.	Stainless St.

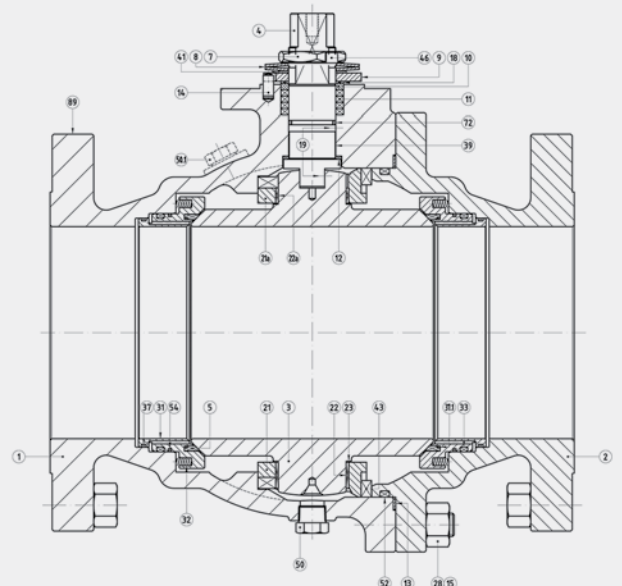
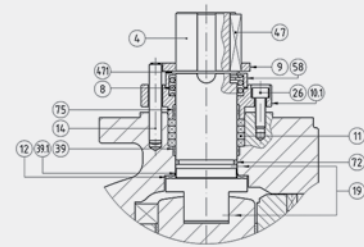

(*) On request Inconel X-750.

(**) On request B7M / 2HM Zinc Plated & Bichromated.

Note 1: Depending on design conditions AFLAS, KALREZ or KALREZ Spectrum.

Note 2: Only DN-350 & 400 and all Fig.2560.

CAST BALL VALVES 2515 / 2530 / 2560
Class 150 / 300 / 600
Full Bore
Class 150. From 2" to 16"
Class 300. From 2" to 16"
Class 600. From 2" to 12"

 DN 50 (2") to DN-250 (10") Class-150 & 300
 DN-50 (2") to DN-100 (4") Class-600

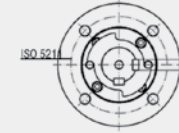
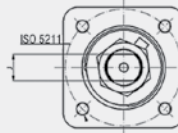
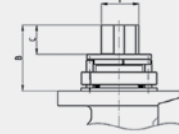
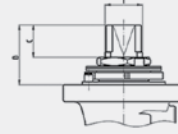
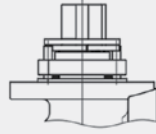
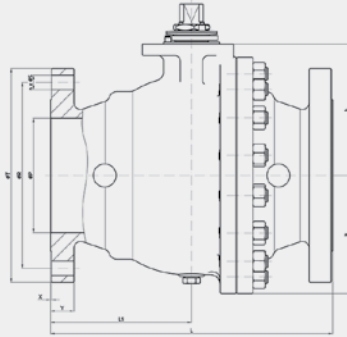
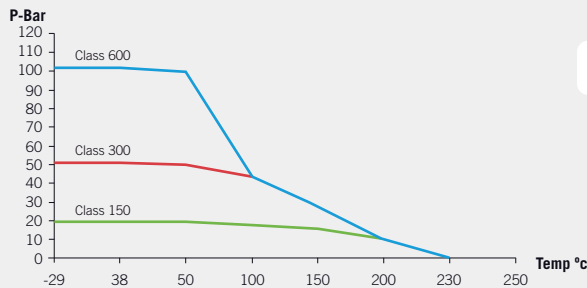
 DN 300 (12") to DN-400 (16") Class-150 & 300
 DN-150 (6") to DN-300 (12") Class-500

Pressure - Temperature

(*) Dimensions of diameters of drills ISO 5211 refer to table from page 60.

Fig. 2515 (Class 150)

DN	øP	L	L1	øR	n x øS	øT	h	N	ISO 5211	B	C	I	J	K	WEIGHT	TORQUE	Kv
50 (2")	50	178	78.5	120.7	4x19	150	84	80	F07	42	17	M22x1,5	16	-	13	70	366
80 (3")	80	203	87	152.4	4x19	190	126	-	F10	55	27	M28x1,5	20	-	22	130	938
100 (4")	100	229	101	190.5	8x19	230	152	120	F12	56	27	M35x2	25	-	39	190	1.465
150 (6")	151	394	197	241.3	8x22.2	280	212	168	F14	70	36	M45x2	32	-	98	460	3.297
200 (8")	203	457	230	298.5	8x22.2	345	233	208	F14	70	37	M45x2	32	-	124	610	5.861
250 (10")	254	533	267	362	12x25.4	405	256	243	F14	70	37	M45x2	32	-	175	660	9.454
300 (12")	305	610	305	431.8	12x25.4	485	297	287.5	F14	106	58	50	14	53.5	295	1.317	13.631
350 (14")	337	686	343	476.3	12x28.5	535	333	323	F16	103	49	60	18	64.2	580	2.605	16.641
400 (16")	388	762	381	539.8	16x28.5	595	412	358	F25	159	103	90	25	95.3	750	2.948	23.554

Fig. 2530 (Class 300)

DN	øP	L	L1	øR	n x øS	øT	h	N	ISO 5211	B	C	I	J	K	WEIGHT	TORQUE	Kv
50 (2")	50	216	84	127	8x19	165	84	-	F07	42	17	M22x1,5	16	-	16	80	366
80 (3")	80	283	115	168.3	8x22.2	210	126	-	F10	55	27	M28x1,5	20	-	33	140	938
100 (4")	100	305	133	200	8x22.2	255	152	-	F12	56	27	M35x2	25	-	43	240	1.465
150 (6")	151	403	202	269.9	12x22.2	320	212	173	F14	70	36	M45x2	32	-	113	598	3.297
200 (8")	203	502	252	330.2	12x25.4	380	233	210	F14	70	37	M45x2	32	-	157	1.400	5.861
250 (10")	254	568	284	387.4	16x28.5	445	257	253	F14	70	37	M45x2	32	-	263	1.604	9.454
300 (12")	305	648	315	450.8	16x31.8	520	310	300	F16	103	49	60	18	64.2	480	2.310	13.631
350 (14")	337	762	381	514.4	20x34.9	585	333	331	F16	103	49	60	18	64.2	655	3.642	16.641
400 (16")	388	838	419	571.5	20x34.9	650	412	365	F25	159	103	90	25	95.3	890	3.900	23.554

Fig. 2560 (Class 600)

DN	øP	L	L1	øR	n x øS	øT	h	N	ISO 5211	B	C	I	J	K	WEIGHT	TORQUE	Kv
50 (2")	50	292	96	127	8x19.1	165	84	-	F07	42	17	M22x1,5	16	-	20	90	366
80 (3")	80	356	140	168.3	8x22.2	210	126	113	F10	55	27	M28x1,5	20	-	41	170	938
100 (4")	100	432	160	215.9	8x25.2	275	152	-	F12	56	27	M35x2	25	-	77	392	1.465
150 (6")	151	559	246	292.1	12x28.5	355	212	188	F14	97	49	45	14	48.5	192	1.007	3.297
200 (8")	203	660	315	349.2	12x31.8	420	237	235	F14	113	64	50	14	53.5	329	2.057	5.861
250 (10")	254	787	340	431.8	16x34.9	510	275	273	F16	103	49	60	18	64.2	460	3.013	9.454
300 (12")	305	838	404	489	20x34.9	560	345	335	F16	127	73	65	18	69.2	570	5.500	13.631

 (*) Dimensions in mm and weight in kg.
 (**) Weights and dimensions can be changed without notice.

| BALL VALVES |

FLOATING ASME

1/2" - 12" | Class 150 - Class 1500

A floating ball valve is a valve with seats supported ball, that is pushed by upstream pressure towards the downstream seat to ensure sealing. The DN of the floating ball valves range is limited by the capability of the seats material to support the pressure, temperature and weight of the ball.

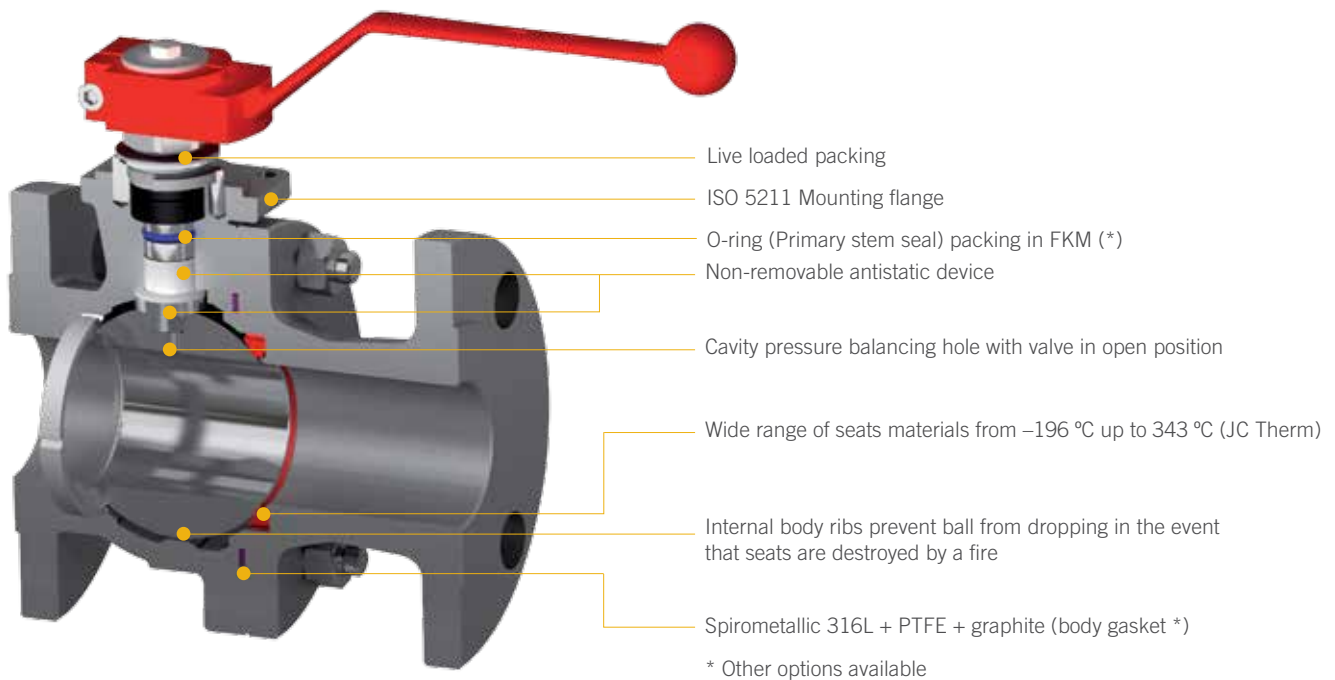

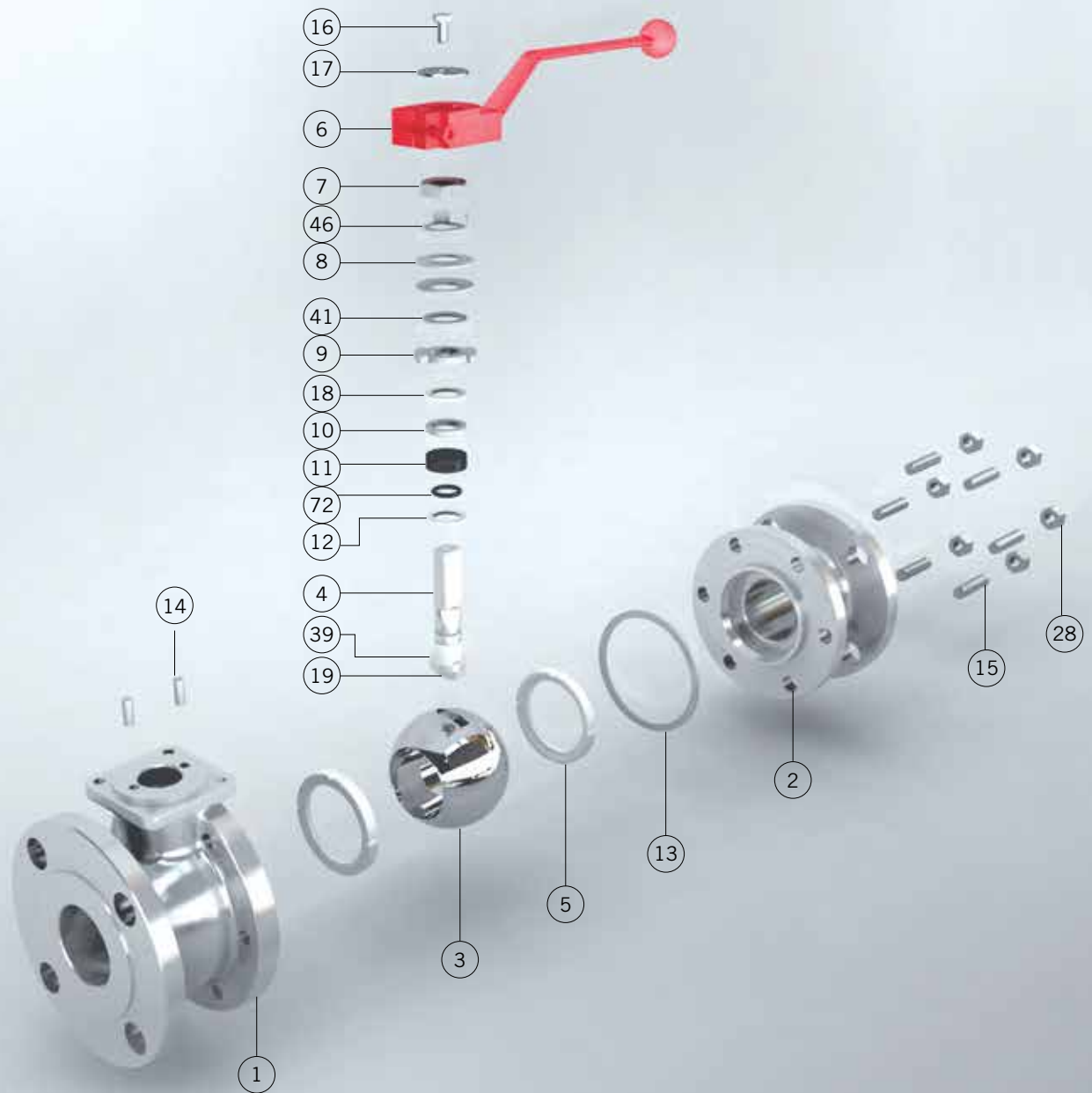

Materials ASME

Item	Description	AIT	LIT	IIT
1	Body	A 216 Gr. WCB (C ≤ 0,25%)	A 352 Gr. LCC	A 351 Gr. CF8M
2	Body connector	A 216 Gr. WCB (C ≤ 0,25%)	A 352 Gr. LCC	A 351 Gr. CF8M
3	Ball		A 351 Gr. CF8M (DN 15 : 50 A 479 Tp.316)	
4	Stem		A 479 Tp.316	
5	Seat ring		PTFE, PEEK, NYLON, DEVLON	
6	Wrench		Nodular Iron	
7	Gland nut	Zinc plated carbon steel	AISI 303	AISI 303
8	Disk spring	Carbon St.	A 666 Tp.301	A 666 Tp.301
9	Stop plate	Carbon St.	AISI 304	AISI 304
10	Gland	AISI 303	AISI 316	AISI 316
11	Gland packing		Graphite	
12	Stem thrust seal		25% G.F. PTFE	
13	Body connector seal		AISI 316L + PTFE + Graphite	
14	Stop pin	Carbon St.	Stainless St.	Stainless St.
15	Stud	A 193 Gr. B7M Zinc dichromate	A 193 Gr. L7M + Zinc dichromate	A 193 Gr. B8M
16	Bolt	DIN 933 5.6 Zinc plated	DIN 933 A2	DIN 933 A2
17	Washer	Zinc plated carbon steel	AISI 304	AISI 304
18	Thrust washer		25% G.F. PTFE	
19	Antistatic device		Stainless St.	
28	Nut	A 194 Gr. 2HM Zinc dichromate	A 194 Gr. 7M + Zinc dichromate	A 194 Gr. 8M
39	Stem bushing (DN 25 to 200)		25% G.F. PTFE	
41	Spacer (DN 40 to 200)	Carbon St.	AISI 304	AISI 304
46	Washer	AISI-304	AISI 304	AISI 304
72	"O" Ring		FKM	
89	Identification plate		Stainless St.	

ASME 515 / 530

Class 150 / 300

Full Bore

Class 150. From ½" to 8"

Class 300. From ½" to 6"

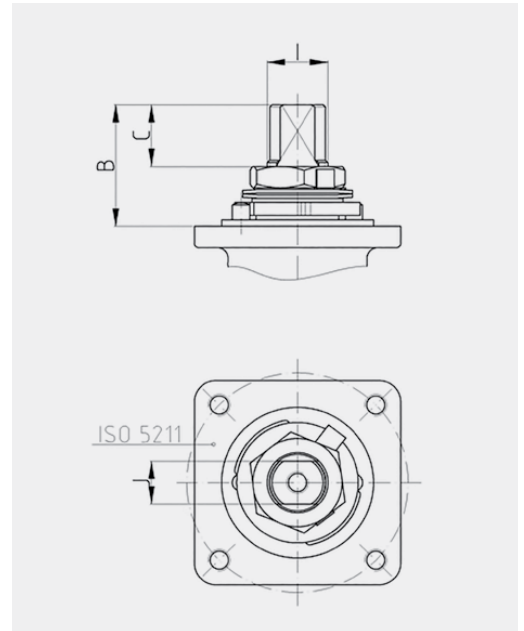
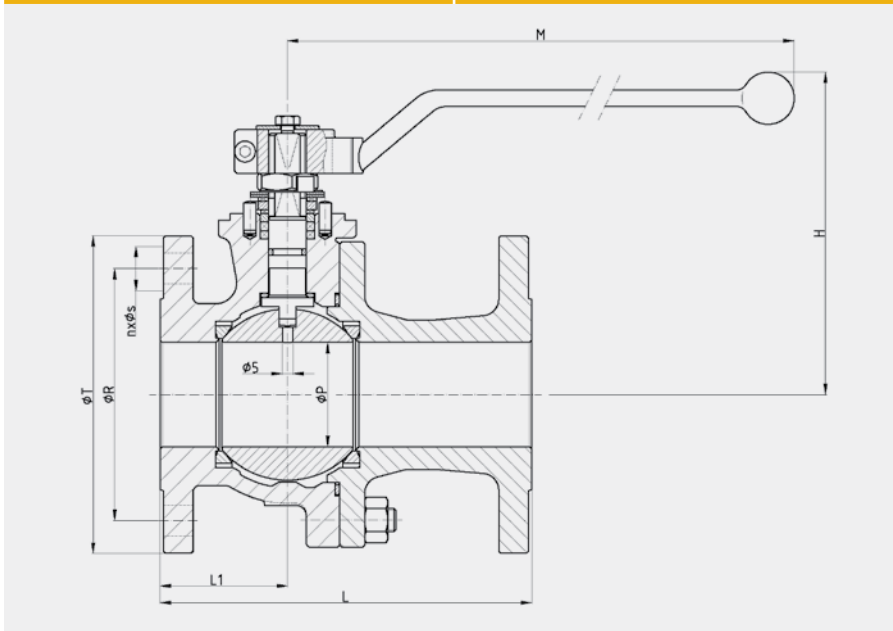

(*) Dimensions of diameters of drills ISO 5211 refer to table from page 60.

Pressure - Temperature

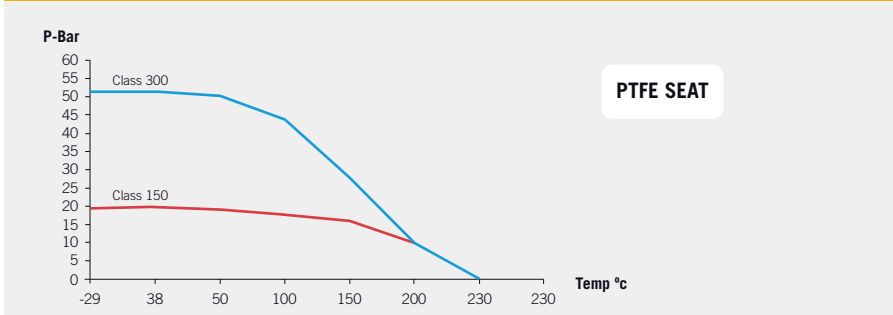

Fig. 515 (Class 150)

DN	ØP	L	L1	ØR	n x ØS	ØT	H	M	ISO 5211	B	C	I	J	WEIGHT	TORQUE	Kv
15 (½")	15	108	47	60,3	4x15,9	90	110	164	F05	11,2	5,7	M12x1.5	9	2	8	20
20 (¾")	20	117	50	69,9	4x15,9	100	117	164	F05	13,2	9,2	M12x1.5	9	3	10	40
25 (1")	25	127	52	79,4	4x15,9	110	129	164	F05	22,7	10,2	M12x1.5	9	3,5	15	75
40 (1 ½")	40	165	65	98,4	4x15,9	125	148	213	F07	41,5	19,2	M18x1.5	13	8	25	170
50 (2")	50	178	61	120,7	4x19	150	155	213	F07	41,5	19,2	M18x1.5	13	11	40	270
65 (2 ½")	65	190	75	139,7	4x19	180	169	348	F07	44	19,7	M22x1.5	16	16	60	550
80 (3")	80	203	79	152,4	4x19	190	207	445	F10	44,5	19,7	M25x1.5	18	23	90	1000
100 (4")	100	229	90	190,5	8x19	230	231	495	F10	56,5	29,2	M28x1.5	20	38	150	1650
150 (6")	151	394	174	241,3	8x22,2	280	298	698	F12	68	38,5	M40x1.5	29	88	250	4200
200 (8")	203	457	200	298,5	8x22,2	345	352	868	F14	72	39	M45x2	32	155	700	9000

Fig. 530 (Class 300)

DN	ØP	L	L1	ØR	n x ØS	ØT	H	M	ISO 5211	B	C	I	J	WEIGHT	TORQUE	Kv
15 (½")	15	140	60	66,7	4x15,9	95	110	164	F05	11,2	5,7	M12x1.5	9	3	12	20
20 (¾")	20	152	65	82,6	4x19	115	117	164	F05	13,2	9,2	M12x1.5	9	4	16	40
25 (1")	25	165	70	88,9	4x19	125	129	164	F05	22,7	10,2	M12x1.5	9	5	20	75
40 (1 ½")	40	190	80	114,3	4x22,2	155	148	213	F07	41,5	19,2	M18x1.5	13	11	35	170
50 (2")	50	216	83	127	8x19	165	155	213	F07	41,5	19,2	M18x1.5	13	14	55	270
80 (3")	80	283	118	168,3	8x22,2	210	207	445	F10	44,5	19,7	M25x1.5	18	32	150	1000
100 (4")	100	305	133	200	8x22,2	255	231	495	F10	56,5	29,2	M28x1.5	20	52	230	1650
150 (6")	151	403	160	269,9	12x22,2	320	298	698	F12	68	38,5	M40x1.5	29	94	342	4200

(*) Dimensions in mm, weight in kg and Torque in Nm.
(**) Weights and dimensions can be changed without notice.

ASME 715 / 730

Class 150 / 300

Reduced Bore

Class 150. From 1/2" to 12"

Class 300. From 1/2" to 8"

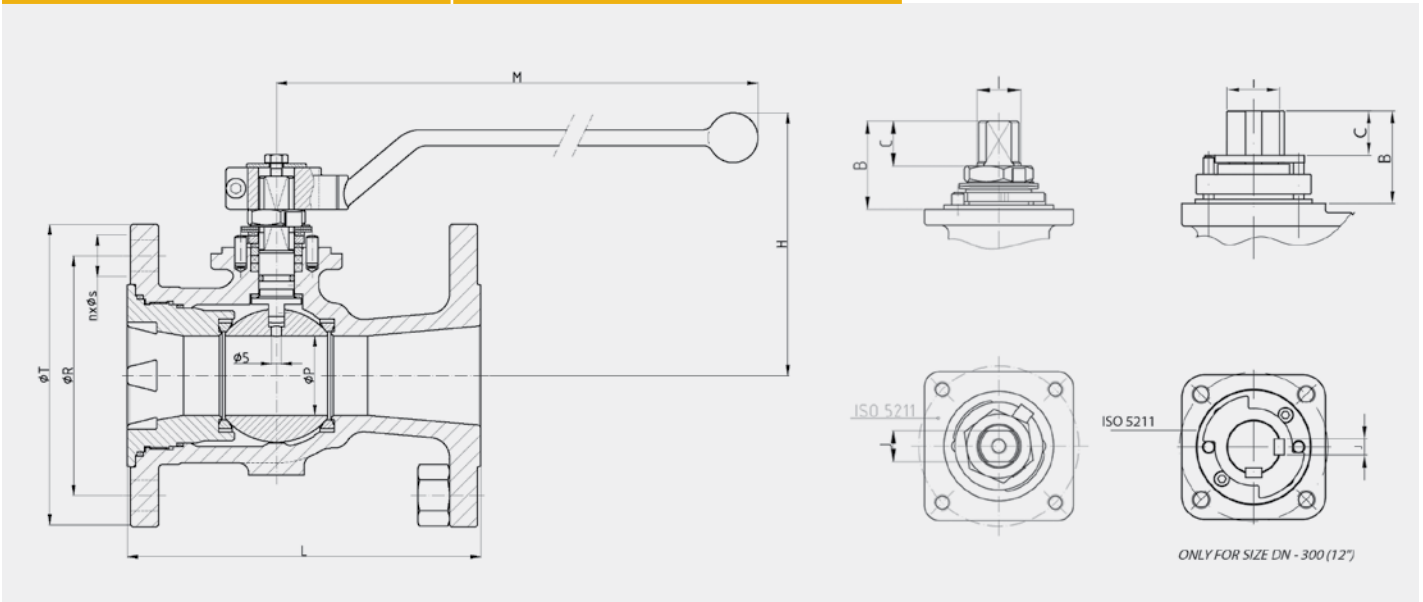

(*) Dimensions of diameters of drills ISO 5211 refer to table from page 60.

Pressure - Temperature

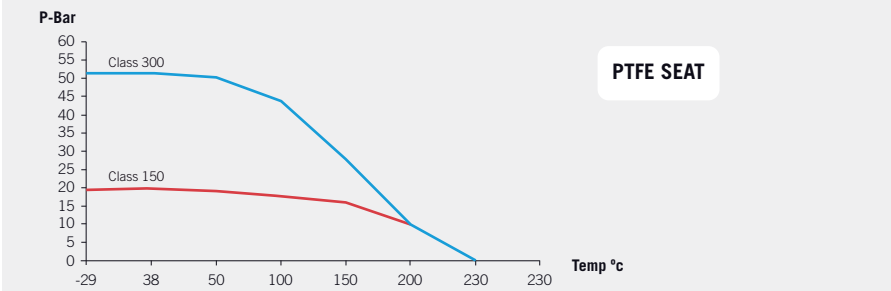

Fig. 715 (Class 150)

DN	ØP	L	L1	ØR	n x ØS	ØT	H	M	ISO 5211	B	C	I	J	WEIGHT	TORQUE	Kv
15 (1/2")	9,5	108	54	60,3	4x15,9	90	81	164	F05	22	8,3	M10x1.5	7	1,6	6	7
20 (3/4")	15	117	60	69,9	4x15,9	100	98	164	F05	22,7	9	M12x1.5	9	2,1	9	10
25 (1")	20	127	65	79,4	4x15,9	110	101	164	F05	22,7	9	M12x1.5	9	2,7	11	26
40 (1 1/2")	32	165	72	98,4	4x15,9	125	117	210	F05	34,5	14,7	M16x1.5	12	5,1	17	107
50 (2")	40	178	75,1	120,7	4x19	150	134	213	F07	41,5	19,2	M18x1.5	13	7,9	26	140
80 (3")	58	203	88	152,4	4x19	190	149	348	F07	44	19,7	M22x1.5	16	14,3	58	300
100 (4")	80	229	104,1	190,5	8x19	230	189	445	F10	44,5	19,7	M25x1.5	18	25,9	90	600
150 (6")	111	267	125	241,3	8x22,2	280	227	495	F12	56,5	29,2	M28x1.5	20	43,8	210	1000
200 (8")	144	292	135	298,5	8x22,2	345	264	698	F12	68	38,5	M40x1.5	29	77	320	2000
250 (10")	187	330	164	362	12x25,4	405	307	698	F12	72	39	M45x2	32	114	650	4100
(1) 300 (12")	228	356	178	431,8	12x25,4	485	-	-	F14	106	58	Ø50	14	230	980	6900

Fig. 730 (Class 300)

DN	ØP	L	L1	ØR	n x ØS	ØT	H	M	ISO 5211	B	C	I	J	WEIGHT	TORQUE	Kv
15 (1/2")	9,5	140	54	66,7	4x15,9	95	81	164	F05	22	8,3	M10x1.5	7	1,6	10	7
20 (3/4")	15	152	60	82,6	4x19	115	98	164	F05	22,7	9	M12x1.5	9	2,1	12	10
25 (1")	20	165	65	88,9	4x19	125	101	164	F05	22,7	9	M12x1.5	9	4,1	16	26
40 (1 1/2")	32	190	72	114,3	4x22,2	155	117	210	F05	34,5	14,2	M16x1.5	12	8,2	26	107
50 (2")	40	216	75,1	127	8x19	165	134	213	F07	41,5	19,2	M18x1.5	13	10,9	35	140
80 (3")	58	283	88	168,3	8x22,2	210	149	348	F07	41,5	19,2	M18x1.5	13	21,4	60	300
100 (4")	80	305	104,1	200	8x22,2	255	189	445	F10	44,5	19,7	M25x1.5	18	28,9	90	600
150 (6")	111	403	125	269,9	12x22,2	320	227	495	F12	56,5	29,2	M28x1.5	20	70	280	1000
200 (8")	144	419	135	330,2	12x25,4	380	264	698	F12	68	38,5	M40x1.5	29	110,5	570	2000

(*) Dimensions in mm, weight in kg and Torque in Nm.
 (**) Weights and dimensions can be changed without notice.
 (1) Body and Body connector joint is not threaded, is with screws.

ASME 560
Class 600
Full Bore

Class 600. From ½" to 4"

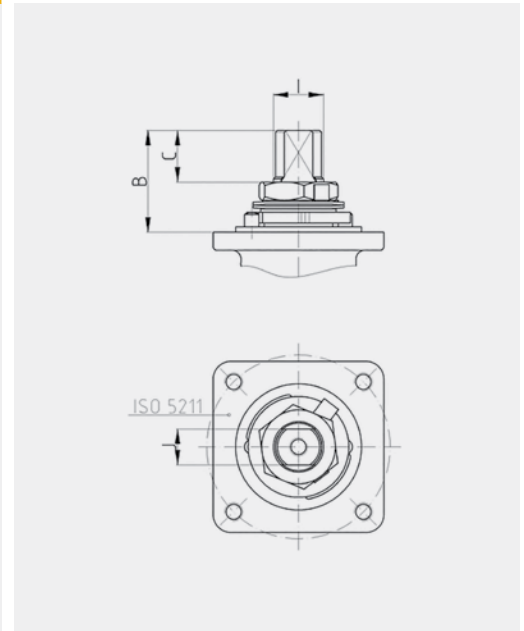
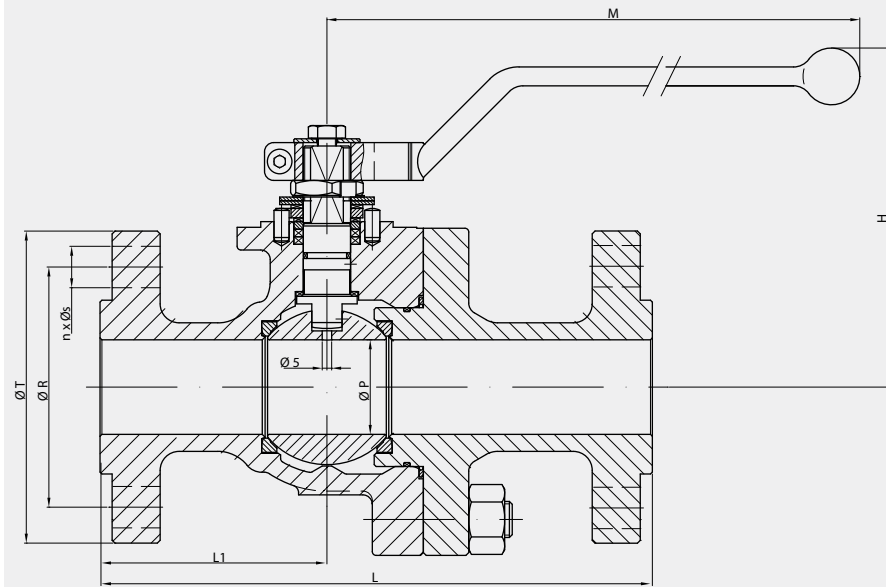

(*) Dimensions of diameters of drills ISO 5211 refer to table from page 60.

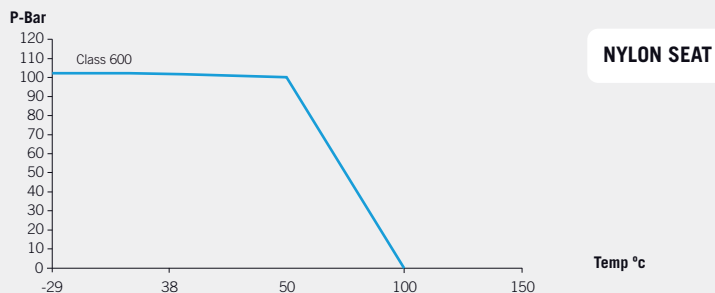
Pressure - Temperature

Fig. 560 (Class 600)

DN	ØP	L	L1	ØR	n x ØS	ØT	H	M	ISO 5211	B	C	I	J	WEIGHT	TORQUE	Kv
15 (½")	15	165	70	35	4x15,8	95,3	111	163,5	F05	11,2	5	12	9	5,5	20	22
20 (¾")	20	190	86	43	4x19	117,3	117	163,5	F05	23,7	10,5	12	9	8	25	43
25 (1")	25	216	94	50,3	4x19	124	119	210	F05	33,5	13	16	12	10	65	81
40 (1 ½")	40	241	104	73	4x22,2	155,4	137	347,5	F07	43	17,6	22	16	19	80	224
50 (2")	50	292	120	127	8x19	165	180	445	F10	45	20,2	M25x1.5	18	29	110	270
80 (3")	80	356	151	168,3	8x22,2	210	228	698	F12	55,5	27	M35x2	25	42	270	1000
100 (4")	100	432	172	215,9	8x25,4	275	245	698	F12	55	26,5	M35x2	25	78	484	1650

 (*) Dimensions in mm, weight in kg and Torque in Nm.
 (**) Weights and dimensions can be changed without notice.

ASME 660

Class 600

Reduced Bore

Class 600. From 2" to 4"

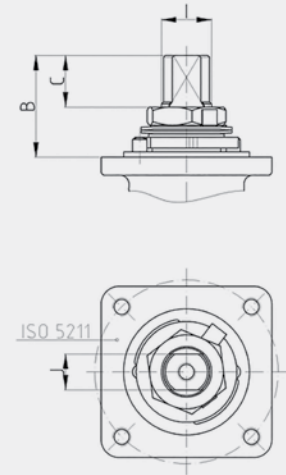
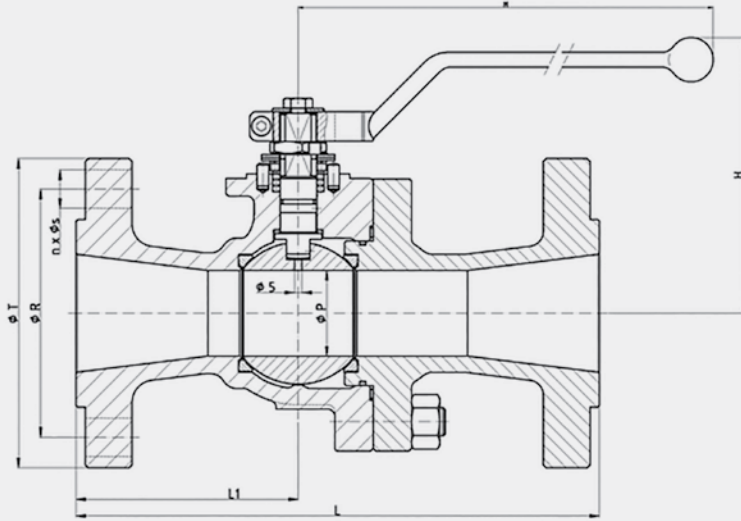

(*) Dimensions of diameters of drills ISO 5211 refer to table from page 60.

Pressure - Temperature

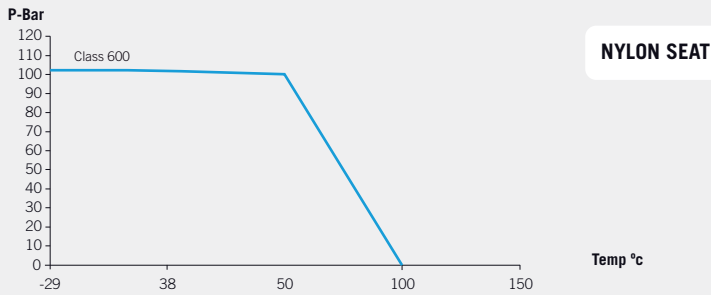

Fig. 660 (Class 600)

DN	ϕP	L	L1	ϕR	n x ϕS	ϕT	H	M	ISO 5211	B	C	I	J	WEIGHT	TORQUE	Kv
50 (2")	40	292	120	127	8x19	165	137	348	F07	43	18,7	M22x1.5	16	17	80	140
80 (3")	58	356	151	168.3	8x22,2	210	228	698	F10	44	19,2	M25x2	18	30	130	300
100 (4")	80	432	190	215.9	8x25.4	275	228	698	F10	55,5	27	M35x2	25	64	300	600

(*) Dimensions in mm, weight in kg and Torque in Nm.
 (**) Weights and dimensions can be changed without notice.

| BALL VALVES |

3 PIECE FORGED BALL VALVES ASME

From ¼" to 2" | Class 800 - Class 1500

Forging is a manufacturing process where metal is shaped by plastic deformation under great pressure into high strength parts. The JC 3 piece forged ball valves are designed with excellent Mechanical properties, yield strength, ductility, toughness, Reliability (used for critical applications).

LOCKING DEVICE



STEM EXTENSION

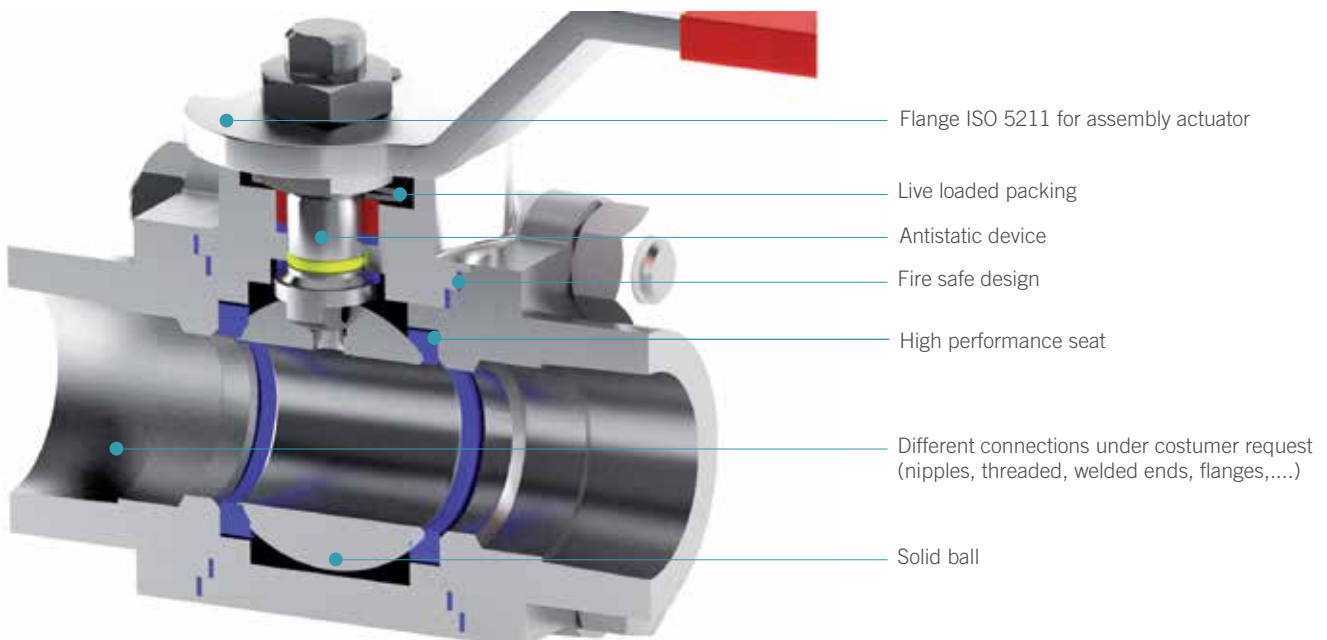

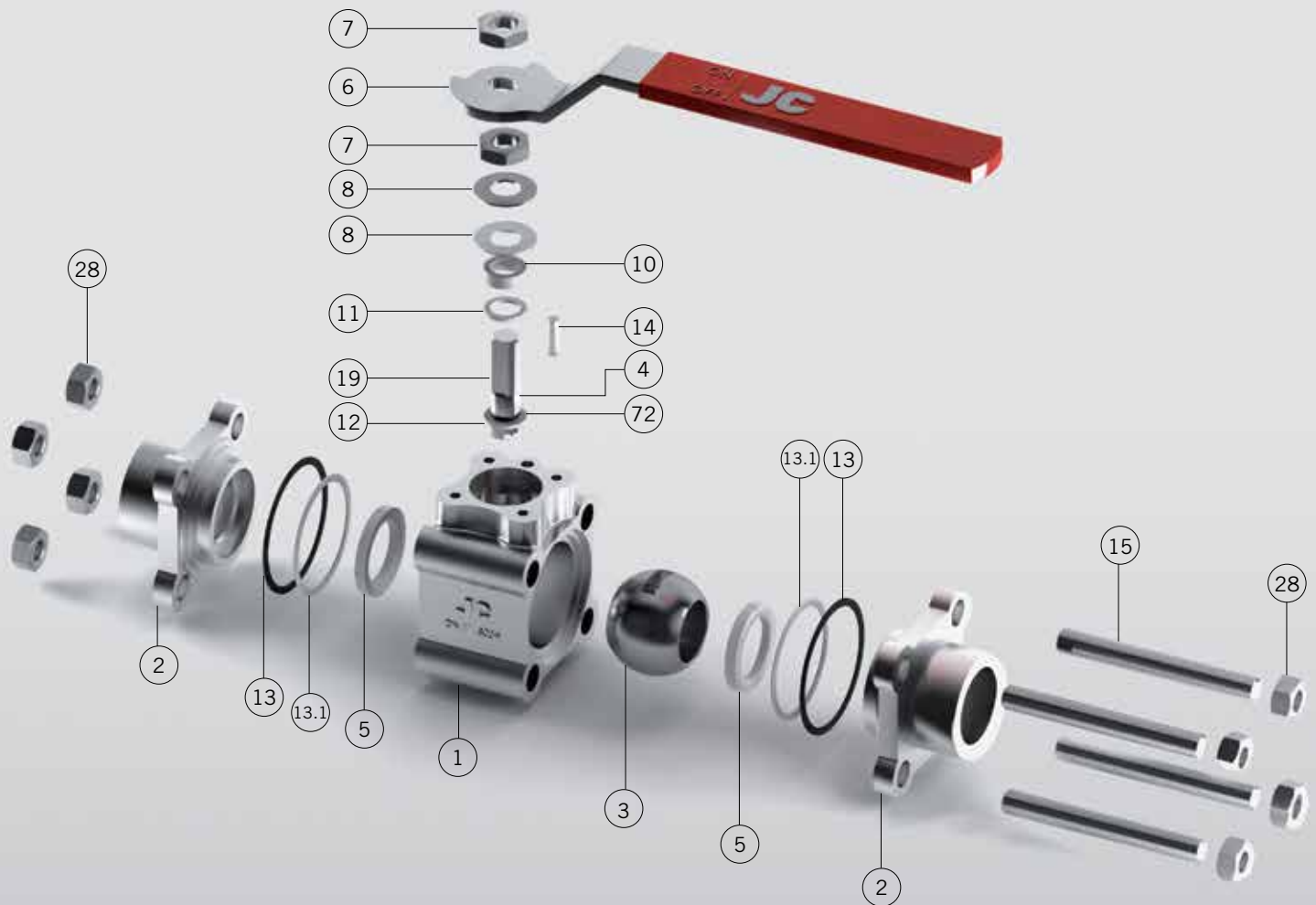

Materials

800

81500

Item	Description	Carbon Steel	Stainless Steel	Carbon Steel	Stainless Steel
1	Body	ASTM A105	ASTM A182 Gr. F316	ASTM A105 / A350 LF2	ASTM A182 Gr. F316
2	End Connector	ASTM A105	ASTM A182 Gr. F316	ASTM A105 / A350 LF2	ASTM A182 Gr. F316
3	Ball	A 479 Tp. 316	A 479 Tp. 316	A 479 Tp. 316	A 479 Tp. 316
4	Stem	A 479 Tp. 316	A 479 Tp. 316	A 479 TP410	17-4-PH
5	Seat ring	TFM-1600+CG	TFM-1600+CG	DEVLON "V" (*)	DEVLON "V" (*)
6	Wrench	Z.P. Carbon Steel	Z.P. Carbon Steel	Z.P. Carbon Steel	Z.P. Carbon Steel
7	Gland nut	Z.P. Carbon Steel	AISI 316	Z.P. Carbon St.	AISI 316
8	Disk Spring	Carbon Steel	AISI 301	Carbon Steel	AISI 301
10	Gland	AISI 316	AISI 316	AISI 316	AISI 316
11	Gland packing	Graphite	Graphite	Graphite	Graphite
12	Stem thrust seal	PTFE + 25% Graphite	PTFE + 25% Graphite	PTFE + 25% Graphite	PTFE + 25% Graphite
13	Body connector seal	Graphite	Graphite	Graphite	Graphite
13.1	Body connector seal	FKM (**)	FKM (**)	FKM (**)	FKM (**)
14	Stop pin	Stainless Steel	Stainless Steel	Stainless Steel	Stainless Steel
15	Stud	ASTM A 193 B7M	ASTM A 193 B8M	ASTM A 193 B7M	ASTM A 193 B8M
19	Antistatic device	Stainless Steel	Stainless Steel	Stainless Steel	Stainless Steel
28	Nut	ASTM A 194 2HM	ASTM A 194 Gr8M	ASTM A 194 2HM	ASTM A 194 Gr8M
72	O-ring	FKM	FKM	FKM	FKM
89	Identification plate	Stainless Steel	Stainless Steel	Stainless Steel	Stainless Steel

Other materials under request.
 (*) Seats materials under request: DELRIN – PCTFE – NYLON 6.6
 (**) PTFE as an option

ASME 800

Class 800

Full Bore

Class 800. From ¼" to 2"

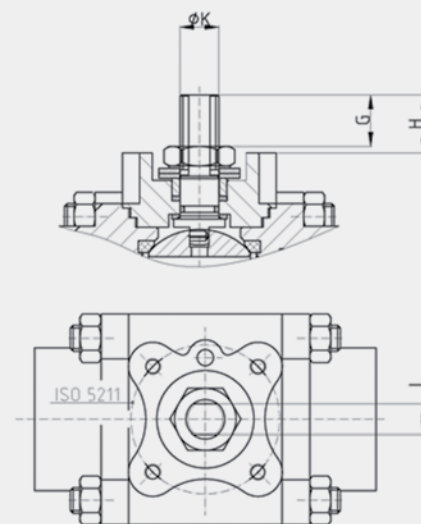
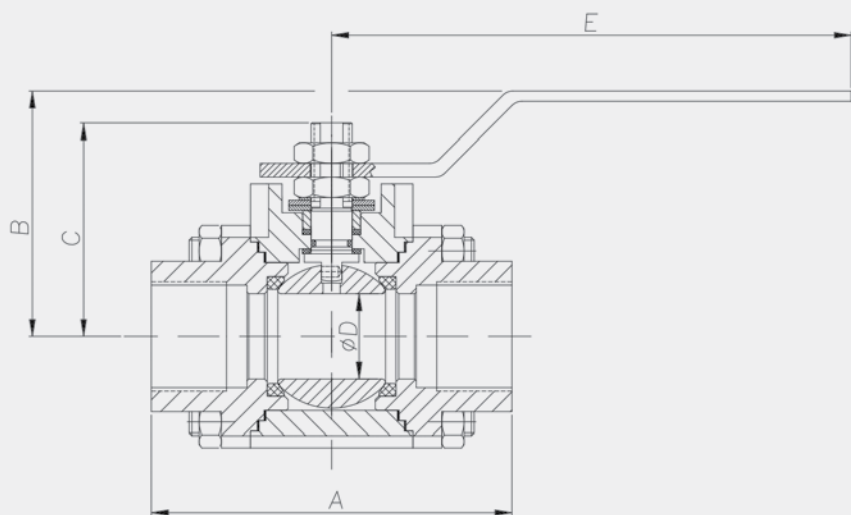

Pressure - Temperature

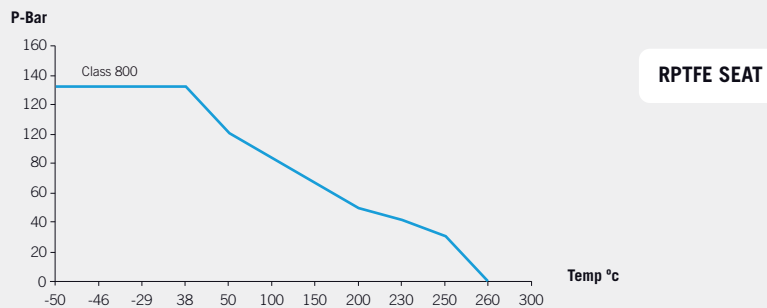

Fig. 800 (Class 800)

DN	A	B	C	ØD	E	ISO 5211	G	H	I	N° x J	ØK	WEIGHT	TORQUE
¼"	68	59	43	9,5	170	36 F03	8,7	10,7	7	4xM5	10	0,8	6
3/8"	68	59	43	9,5	170	36 F03	8,7	10,7	7	4xM5	10	0,8	6
½"	72	59	45	15	170	36 F03	8,7	10,7	7	4xM5	10	1	11
¾"	94	72	59	20	215	42 F04	15,7	17,7	9,5	4xM5	12	1,9	20
1"	106	72	62	25	215	42 F04	15,7	17,7	9,5	4xM5	12	2,5	36
1½"	125,5	109	89	40	245	50 F05	25,2	27,2	9,5	4xM6	16	5,7	64
2"	128	114	89	50	300	50 F05	16,5	25,5	12	4xM6	18	7,6	98

(*) Dimensions in mm and Torque in Nm.

ASME 81500

Class 1500

Full Bore

Class 1500. From 1/4" to 2"

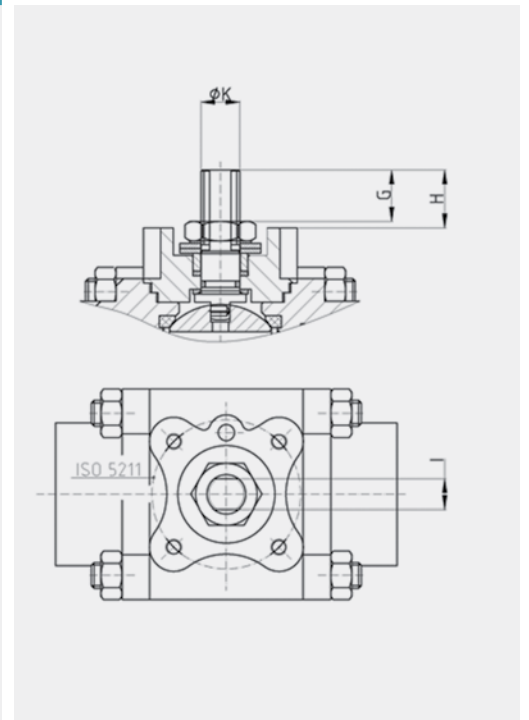
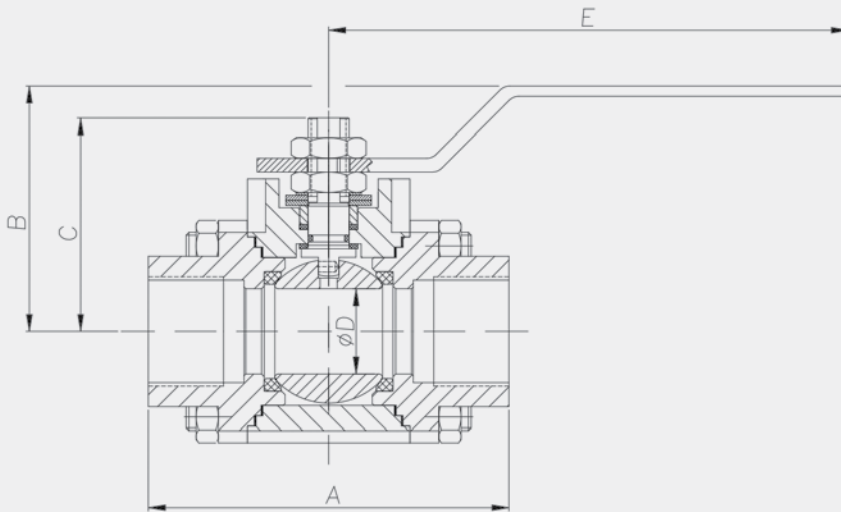

Pressure - Temperature

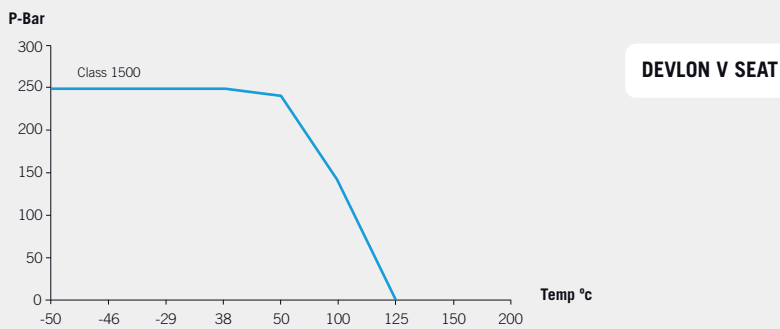

Fig. 81500 (Class 1500)

DN	A	B	C	ØD	E	ISO 5211	G	H	I	N° x J	ØK	WEIGHT	TORQUE
1/4"	84	59	42	9,5	170	36 F03	9,7	10,4	7	4xM5	10	2,2	14
3/8"	84	59	42	9,5	170	36 F03	9,7	10,4	7	4xM5	10	2,2	14
1/2"	104	66	49	15	170	36 F03	9,7	10,4	9	4xM5	12	3,2	20
3/4"	127	86	66	20	245	50 F05	15,6	17,7	9,5	4xM6	16	5,8	29
1"	134	91	70	25	245	50 F05	15,4	17	9,5	4xM6	16	7	43
1 1/2"	200	111	101,5	40	350	70 F07	16	17,6	16	4xM8	22	17	131
2"	222	142	117,7	49	375	70 F07	19	20,4	18	4xM8	25	24	203

(*) Dimensions in mm and Torque in Nm.

| BALL VALVES |

MONOBLOCK VALVES

3/8" - 2" | Class 800 - Class 1500



Materials MONOBLOCK

Item	Description	L.I.CG.	L.I.CG.
1	Body	A 350 Gr. LF2 Class 1	A 479 Tp.316L
2	Body connector	A 350 Gr. LF2 Class 1	A 479 Tp.316L
3	Ball		A 351 Gr. CF8M / A182 F316
4	Stem		AISI 410 / A 479 Tp.316
5	Seat ring		Carbon graphite filled PTFE
6	Wrench (DN-1½" & 2")		Nodular iron
6.1	Wrench (DN-3/8" ~ 1")		AISI-316
7	Gland nut		AISI 303
8	Disk spring		E.N.P. Carbon Steel
9	Stop plate (DN-1½" & 2")		AISI 304
10	Gland		AISI 316
11	Gland packing		Graphite
12	Stem thrust seal		25% G.F. PTFE
14	Stop pin		Stainless St.
16	Bolt (DN-1½" & 2")		DIN 933 A2
17	Washer (DN-1½" & 2")		AISI 304
18	Thrust washer		25% G.F. PTFE
19	Antistatic device		Stainless St.
41	Spacer (DN-40 & 50)		AISI 304
72	"O" Ring		FKM
89	Identification plate		Stainless St.

ASME 400

Class 800

Full Bore

Class 800. From 3/8" to 2"

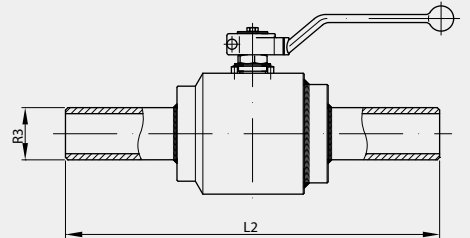
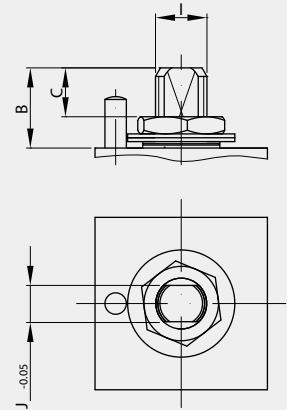
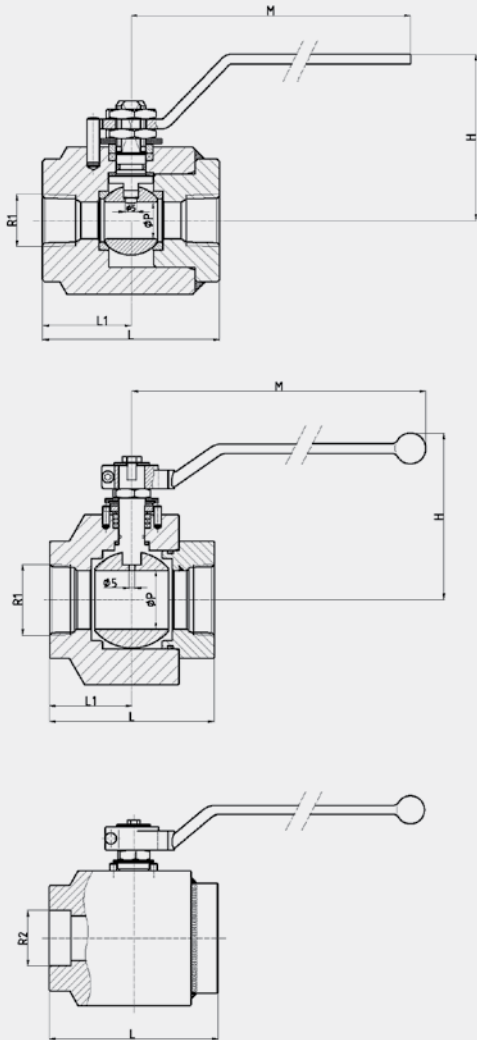

(*) Dimensions of diameters of drills ISO 5211 refer to table from page 60.

Pressure - Temperature

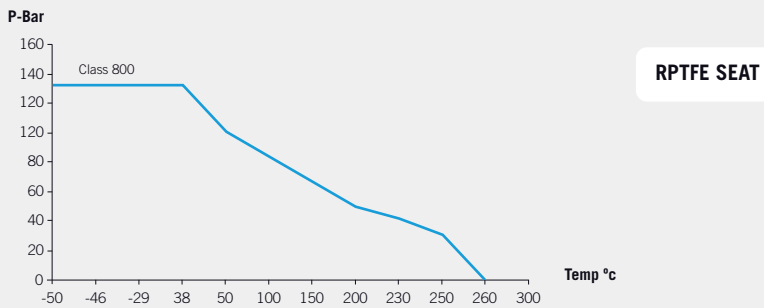

Fig. 400 (Class 800)

DN	øP	L	L2	R1	R2	R3	H	M	B	C	I	J	WEIGHT	TORQUE 20 bar	TORQUE 55 bar	TORQUE 138 bar
3/8"	9,5	70	240	3/8" NPT	3/8" SW	3/8" BW	86	158	16	8,1	M10x1.5	7	1	6	9	16
1/2"	15	72	240	1/2" NPT	1/2" SW	1/2" BW	91	158	18,7	10,6	M12x1.5	9	1,6	8	11	20
3/4"	20	90	240	3/4" NPT	3/4" SW	3/4" BW	94	158	19,2	11,1	M12x1.5	9	2,4	10	14	25
1"	25	95	240	1" NPT	1" SW	1" BW	98	158	19,7	11,1	M12x1.5	9	3,1	15	19	30
1 1/2"	40	130	260	1 1/2" NPT	1 1/2" SW	1 1/2" BW	128	213	38,5	19,2	M18x1.5	13	10	25	78	50
2"	50	140	260	2" NPT	2" SW	2" BW	141	348	41	19,2	M22x1.5	16	14,6	40	129	70

(*) Dimensions in mm and weight in kg.
(**) Weights and dimensions can be changed without notice.

ASME 411N

Class 800

Reduced Bore

Class 800. From 1/2" to 2"

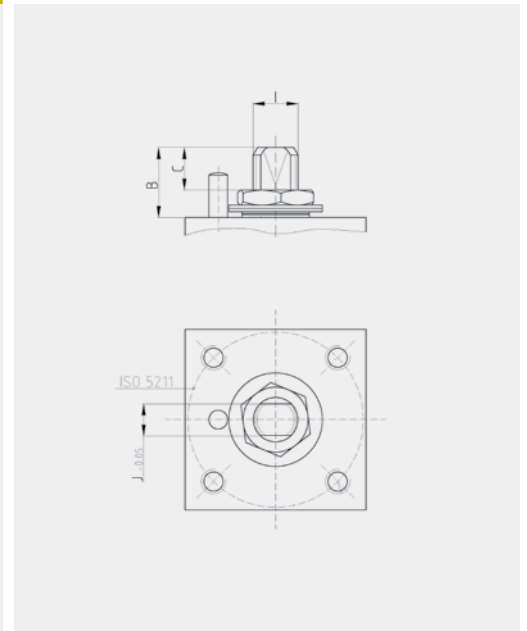
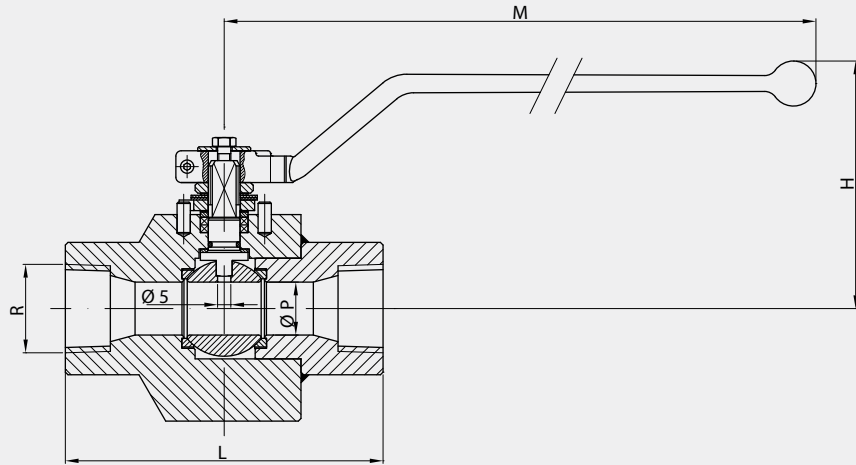

(*) Dimensions of diameters of drills ISO 5211 refer to table from page 60.

Pressure - Temperature

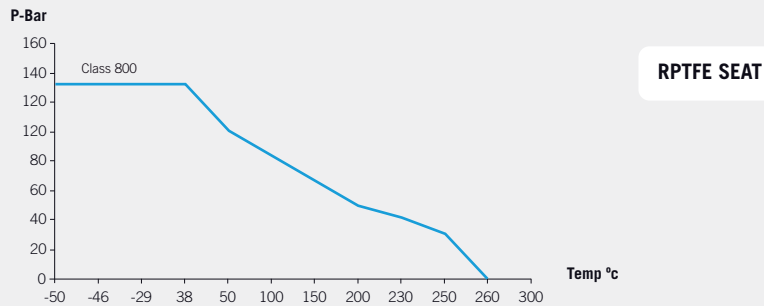

Fig. 411N (Class 800)

DN	øP	L	R	H	M	B	C	I	J	WEIGHT	TORQUE 20 bar	TORQUE 55 bar	TORQUE 138 bar
1/2"	15	90	NPT	101	164	18,7	7,8	M12x1.5	9	3,5	7	10	16
3/4" x 1/2"	15	110	NPT	101	164	18,7	7,8	M12x1.5	9	4,5	7	10	16
1" x 3/4"	20	120	NPT	105	164	20	8,6	M12x1.5	9	5	9	14	25
1 1/2" x 1"	28	150	NPT	111	210	31,5	15,5	M16x1.5	12	6	19	34	71
2" x 1 1/2"	36	180	NPT	128	213	38,5	19,2	M18x1.5	13	10	43	79	164

(*) Dimensions in mm and weight in kg.
 (**) Weights and dimensions can be changed without notice.

ASME 41500

Class 1500

Reduced & Full Bore

Class 1500. From 3/8" to 2"

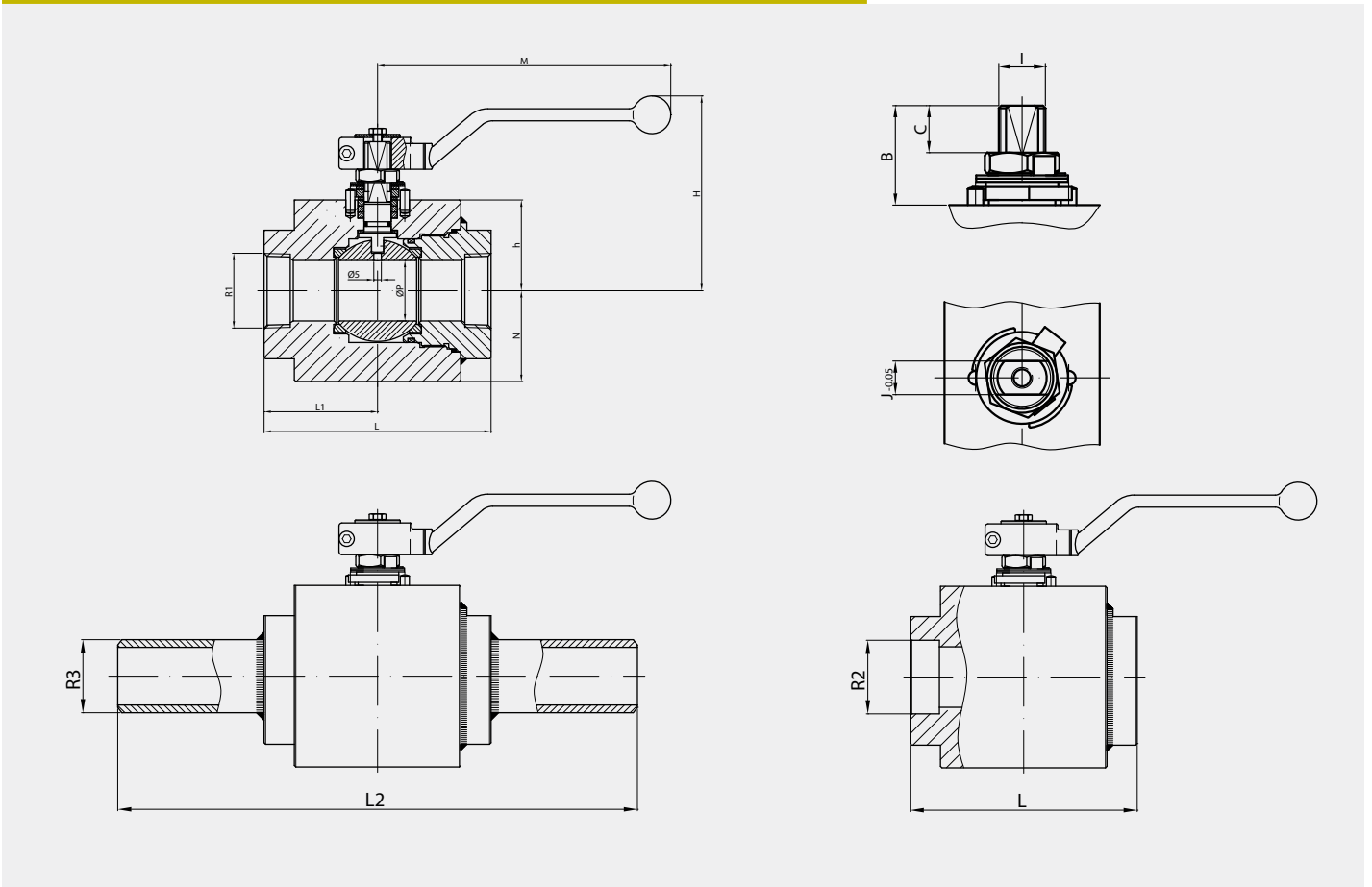

(*) Dimensions of diameters of drills ISO 5211 refer to table from page 60.

Pressure - Temperature

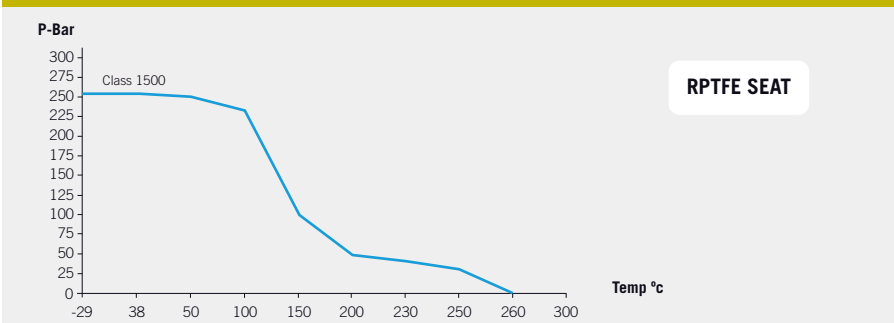

Fig. 41500 (Class 1500)

DN	ØP	L	L1	L2	R1	R2	R3	h	N	H	M	B	C	I	J	TORQUE
3/8"	9,5	80	35	240	3/8" NPT	3/8" SW	3/8" BW	25	25	80,5	164	16	6	M10x1,5	7	11
1/2" x 3/8"	9,5	90	35	250	1/2" NPT	1/2" SW	1/2" BW	25	25	80,5	164	16	6	M10x1,5	7	11
1/2"	15	90	35	250	1/2" NPT	1/2" SW	1/2" BW	29	25	99	164	19,5	8	M12x1,5	9	15
3/4" x 1/2"	15	110	50	270	3/4" NPT	3/4" SW	3/4" BW	29	25	99	164	19,5	8	M12x1,5	9	15
3/4"	20	110	50	270	3/4" NPT	3/4" SW	3/4" BW	32	34	102	164	19,5	8	M12x1,5	9	22
1" x 3/4"	20	119	49	279	1" NPT	1" SW	1" BW	32	34	102	164	19,5	8	M12x1,5	9	22
1"	25	119	49	279	1" NPT	1" SW	1" BW	36	37,5	107	164	19,5	7,5	M12x1,5	9	32
1 1/2" x 1.1/4"	32	150	75	310	1.1/2" NPT	1.1/2" SW	1.1/2" BW	36	37,5	116	210	30,5	14	M16x1,5	12	87
1 1/2"	40	150	75	310	1.1/2" NPT	1.1/2" SW	1.1/2" BW	60	60	128	213	38,5	19	M18x1,5	13	117
2 x 1 1/2"	40	161	66	321	2" NPT	2" SW	2" BW	60	60	128	213	38,5	19	M18x1,5	13	117
2"	50	161	66	321	2" NPT	2" SW	2" BW	73	73	141	348	40,5	19	M22x1,5	16	183

(*) Dimensions in mm, weight in kg and Torque in Nm.
 (**) Weights and dimensions can be changed without notice.

| BALL VALVES |

SEMI-TRUNNION BALL VALVES

8" - 12" | Class 150 - Class 300

DN 200 - DN 300 | PN 16 - PN 40

Materials CAST TRUNNION

Item	Description	AIT	IIT
1	Body	A 216 Gr. WCB (C ≤ 0,25%)	A 351 Gr. CF8M
2	Body connector	A 216 Gr. WCB (C ≤ 0,25%)	A 351 Gr. CF8M
3	Ball	A 351 Gr. CF8M	
4	Stem	A 479 Tp.316	
5	Seat ring	PTFE	PTFE
7	Gland nut	Zinc plated carbon steel	AISI 303
8	Disk spring	Carbon St.	E.N.P. Carbon St.
9	Stop plate	Carbon St.	AISI 304
10	Gland	AISI 303	AISI 316
10.1	Gland	AISI 303	AISI 316
11	Gland packing	Graphite	
12	Stem thrust seal	25% G.F. PTFE	
13	Body connector seal	AISI 316L + Graphite	
14	Stop pin	Carbon St.	Stainless St.
15	Stud	A 193 Gr. B7M Zinc dichromate	A 193 Gr. B8M
18	Thrust washer	25% G.F. PTFE	
19	Antistatic device	Stainless St.	
21 /21a	Ball Trunnion	AISI 316	
22 /22a	Trunnion Bearing	PTFE + 50% SS	
23	Bearing	PTFE	
26	Bolt	DIN 912 8.8 Zinc plated	DIN 912 A2
28	Nut	A 194 Gr. 2HM Zinc dichromate	A 194 Gr. 8M
39	Stem Bushing	25% G.F. PTFE *	
41	Spacer	Carbon St.	Stainless St.
43	Key	AISI 316	
46	Locking washer	AISI 304	
47	Key	AISI 316	
58	Spring Protection	Carbon St.	Stainless St.
72	O Ring	FKM	
89	Identification plate	Stainless St.	
471	Retainer	Steel	Stainless St.

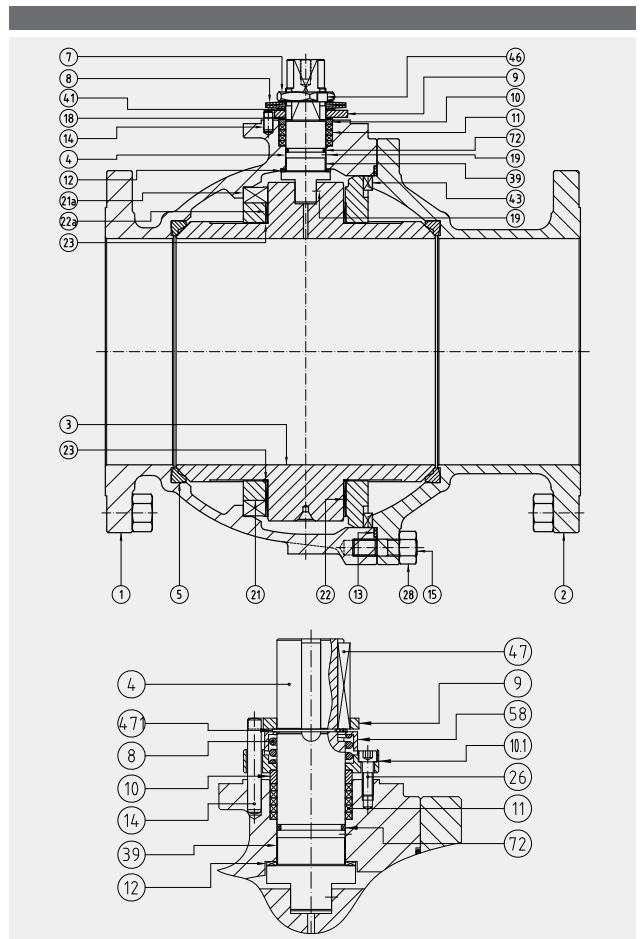

(*) AISI 316 + PTFE only in DN300 (12").

ASME 1515 / 1530

Class 150 / 300

Full Bore

Class 150. From 10" to 12"

Class 300. From 8" to 12"

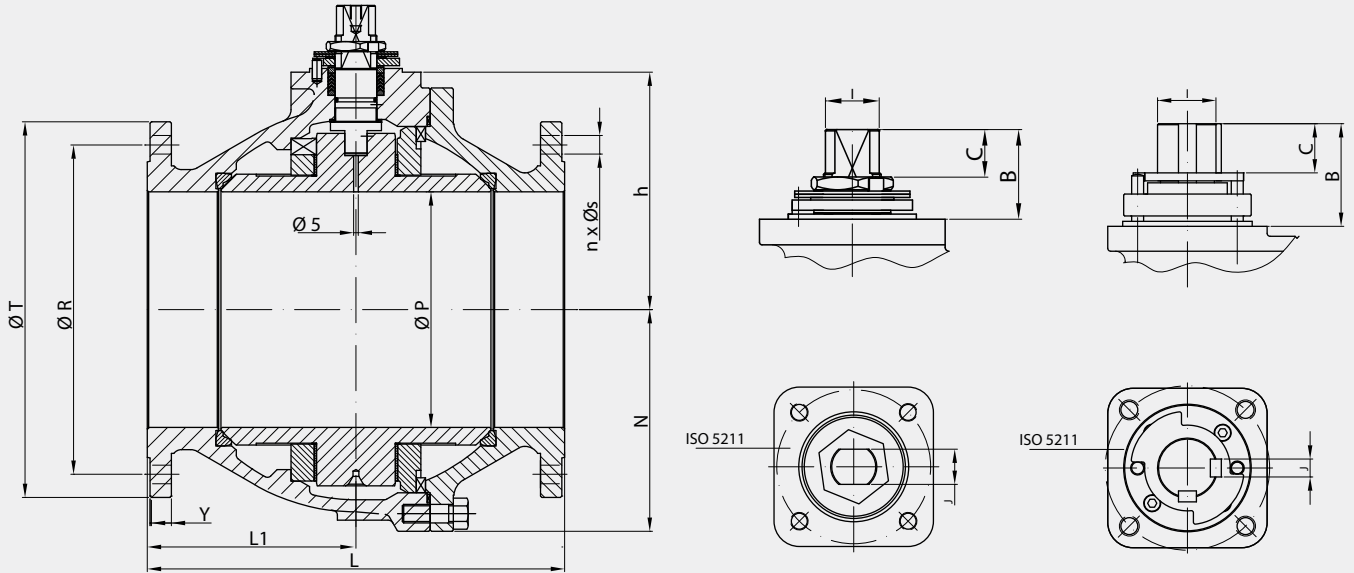

(*) Dimensions of diameters of drills ISO 5211 refer to table from page 60.

Pressure - Temperature

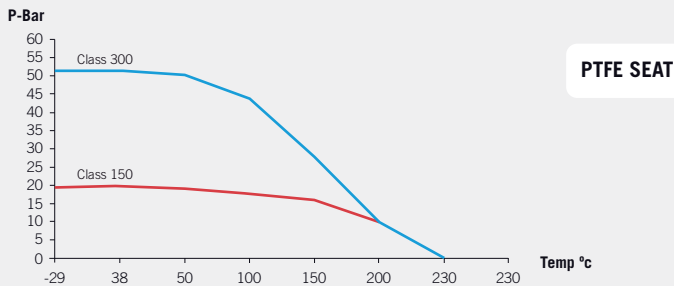

Fig. 1515 (Class 150)

DN	øP	L	L1	øR	n x øS	Y	øT	h	N	ISO 5211	B	C	I	J	WEIGHT	TORQUE	Kv
250 (10")	254	533	225	362	12x25,4	28,7	405	256	239	F14	72	39	M45x2	32	237	1280	15000
300 (12")	305	610	245	431,8	12x25,4	30,2	485	297	287,5	F14	106	58	50	14	357	2000	20800

Fig. 1530 (Class 300)

DN	øP	L	L1	øR	n x øS	Y	øT	h	N	ISO 5211	B	C	I	J	WEIGHT	TORQUE	Kv
200 (8")	203	502	239	330,2	12x25,4	39,6	380	233	208	F14	72	39	M45x2	32	189	1280	9000
250 (10")	254	568	225	387,4	16x28,5	46,2	445	256	252,5	F14	72	39	M45x2	32	301	1480	15000
300 (12")	305	648	315	450,8	16x31,8	49,2	520	310	300	F14	106	58	50	14	520	2550	20800

(*) Dimensions in mm and weight in kg.
(**) Weights and dimensions can be changed without notice.

EN-DIN 1516 / 1540

PN 16 / PN 40

Full Bore

PN 16. From DN 250 to DN 300

PN 40. From DN 200 to DN 300

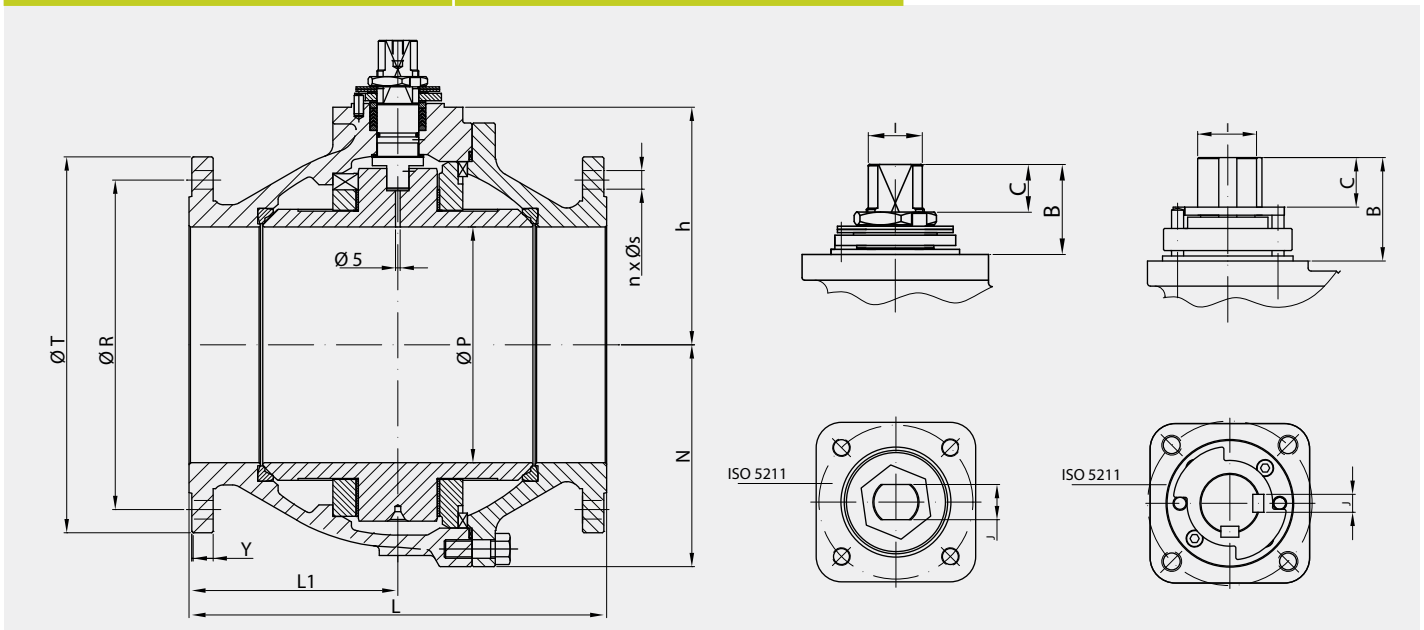

Pressure - Temperature

(*) Dimensions of diameters of drills ISO 5211 refer to table from page 60.
(**) Only DN300

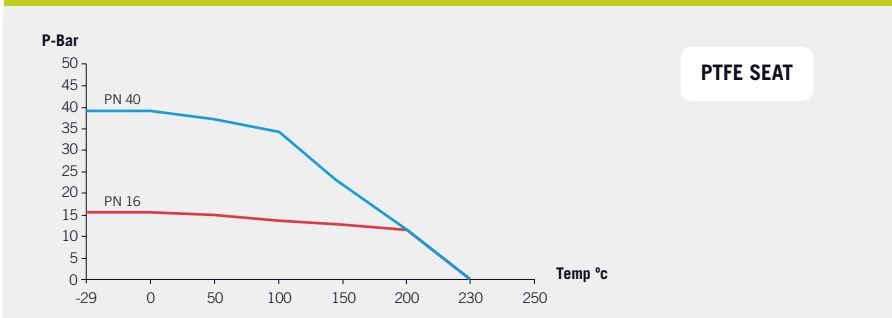

Fig. 1516 (PN 16)

DN	ØP	L	L1	ØR	n x ØS	Y	ØT	h	N	ISO 5211	B	C	I	J	WEIGHT	TORQUE	Kv
250	254	450	225	355	12x26	26	405	256	239	F14	72	39	M45x2	32	223	1120	15000
300	305	500	245	410	12x26	26	460	297	288	F14	106	58	50	14	323	1800	20800

Fig. 1540 (PN 40)

DN	ØP	L	L1	ØR	n x ØS	Y	ØT	h	N	ISO 5211	B	C	I	J	WEIGHT	TORQUE	Kv
200	203	400	200	320	12x30	34	375	233	208	F14	72	39	M45x2	32	162	1000	9000
250	254	450	199	385	12x33	38	450	256	253	F14	72	39	M45x2	32	264	1400	15000
300	305	500	240	450	16x33	42	515	310	300	F14	106	58	50	14	440	2300	20800

(*) Dimensions in mm and weight in kg.
(**) Weights and dimensions can be changed without notice.

JC
VALVES

The quality option



| BALL VALVES |

FLOATING EN-DIN

DN 15 - DN 200 | PN 16 - PN 40

A floating ball valve is a valve with seats supported ball, that is pushed by upstream pressure towards the downstream seat to ensure sealing. The DN of the floating ball valves range is limited by the capability of the seats material to support the pressure, temperature and weight of the ball.

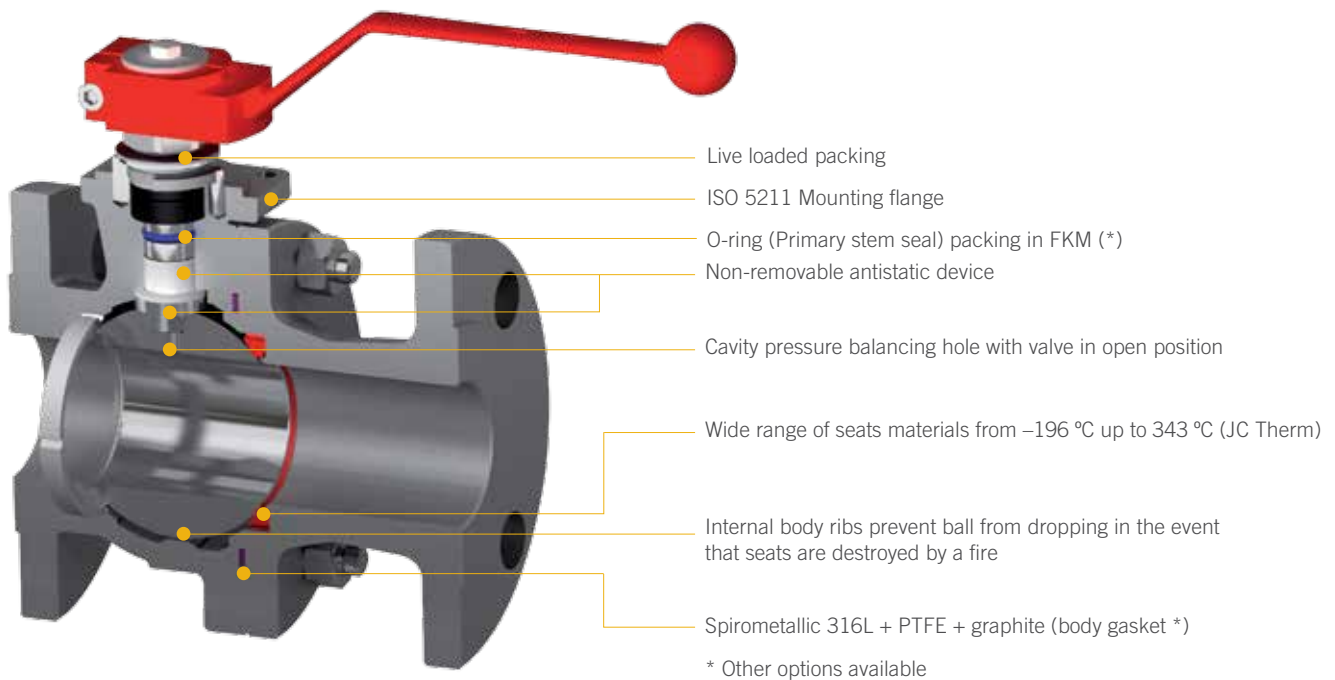

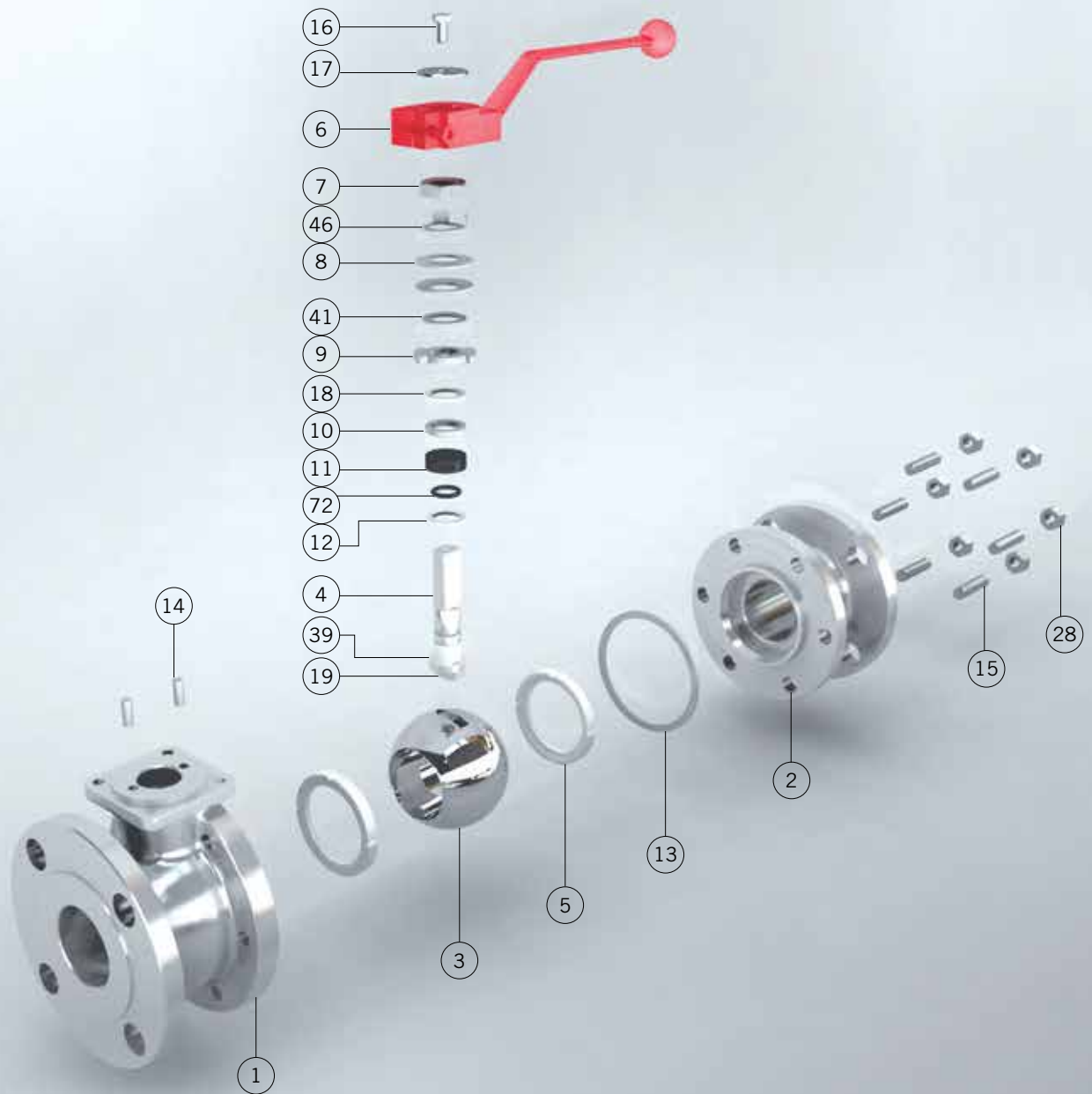

Materials EN-DIN

Item	Description	AIT	IIT
1	Body	1.0619	1.4408
2	Body connector	1.0619	1.4408
3	Ball	A 351 Gr. CF8M (DN 15 : 50 A 479 Tp.316)	
4	Stem	A 479 Tp.316	
5	Seat ring	PTFE	
6	Wrench	Nodular Iron	
7	Gland nut	Zinc plated carbon steel	AISI 303
8	Disk spring	Carbon St.	A 666 Tp.301
9	Stop plate	Carbon St.	AISI 304
10	Gland	AISI 303	AISI 316
11	Gland packing	Graphite	
12	Stem thrust seal	25% G.F. PTFE	
13	Body connector seal	AISI 316L + PTFE + Graphite	
14	Stop pin	Carbon St.	Stainless St.
15	Bolt (DN 32 to DN 100 Stud)	8.8 Zinc Plated & Bichromated	A4-70
16	Bolt	DIN 933 A4-70	
17	Washer	Zinc plated carbon steel	AISI 304
18	Thrust washer	25% G.F. PTFE	
19	Antistatic device	Stainless St.	
28	Nut (DN 32 to DN 100)	DIN 934 .8 Zinc Plated & Bichromated	DIN 934 A4-70
39	Stem bushing (DN 25 to DN 200)	25% G.F. PTFE	
41	Spacer (DN 40 to 200)	Carbon St.	AISI 304
46	Washer	AISI 304	AISI 304
72	"O" Ring	FKM	
89	Identification plate	Stainless St.	

EN-DIN 516 / 540

PN 16 / 40

Full Bore

PN 16. From DN 65 to DN 200

PN 40. From DN 15 to DN 150

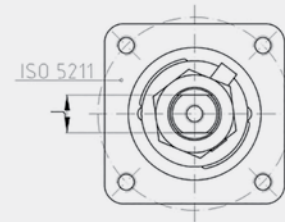
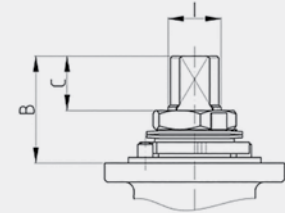
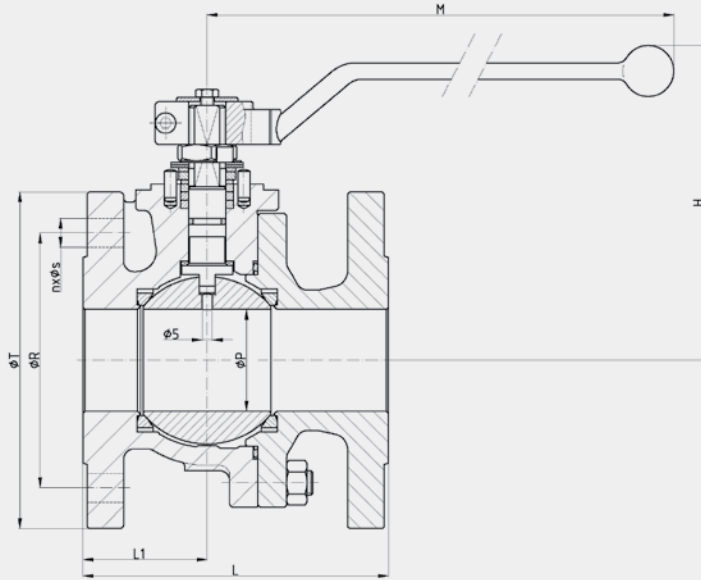

Pressure - Temperature

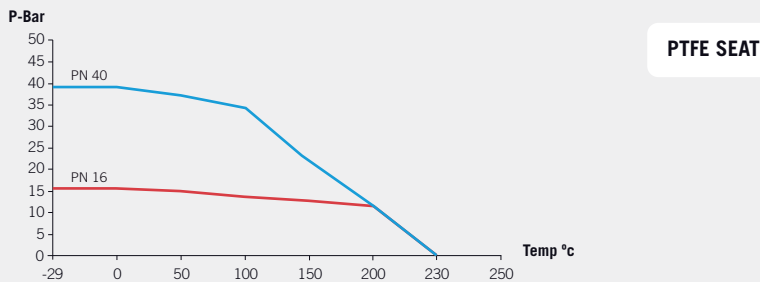

(*) Dimensions of diameters of drills ISO 5211 refer to table from page 60.



Fig. 516 (PN 16)

DN	ØP	L	L1	ØR	n x ØS	ØT	H	M	ISO 5211	B	C	I	J	WEIGHT	TORQUE	Kv
65	65	170	76	145	4x18	185	169	348	F07	44	19,7	M22x1.5	16	16	66	550
80	80	180	82	160	8x18	200	207	445	F10	44,5	18,7	M25x1.5	18	22	91	1000
100	100	190	90	180	8x18	220	231	495	F10	56,5	29,2	M28x1.5	20	32	130	1650
125	125	325	120	210	8x18	250	262	698	F12	56	27,6	M35x2	25	52,5	231	3000
150	151	350	135	240	8x22	285	298	698	F12	68	38,5	M40x1.5	29	76	309	4200
200	203	400	200	295	12x22	340	352	868	F14	72	39	M45x2	32	111	794	9000

Fig. 540 (PN 40)

DN	ØP	L	L1	ØR	n x ØS	ØT	H	M	ISO 5211	B	C	I	J	WEIGHT	TORQUE	Kv
15	15	115	53	65	4x14	95	110	164	F05	11,2	5,7	M12x1.5	9	2,8	11	20
20	20	120	52	75	4x14	105	117	164	F05	13,2	9,2	M12x1.5	9	2,8	13	20
25	25	125	49	85	4x14	115	129	164	F05	22,7	10,2	M12x1.5	9	5	18	75
32	32	130	54	100	4x18	140	131	210	F05	32	13,7	M16x1.5	12	7	23	130
40	40	140	55	110	4x18	150	148	213	F07	41,5	19,2	M18x1.5	13	9	29	170
50	50	150	61	125	4x18	165	155	213	F07	41,5	19,2	M18x1.5	13	12	44	270
65	65	170	76	145	8x18	185	169	348	F07	44	19,7	M22x1.5	16	17	65	550
80	80	180	75	160	8x18	200	207	445	F10	44,5	19,7	M25x1.5	18	23	120	1000
100	100	190	91	190	8x22	235	231	495	F10	56,5	29,2	M28x1.5	20	35	178	1650
125	125	325	120	220	8x26	270	262	698	F12	56	27,6	M35x1.5	25	57	277	3000
150	151	350	135	250	8x26	300	298	698	F12	68	38,5	M40x1.5	29	83,5	464	4200

(*) Dimensions in mm, weight in kg and Torque in Nm.
 (**) Weights and dimensions can be changed without notice.

EN-DIN 316 / 340

PN 16 / 40

Full Bore

PN 16. From DN 65 to DN 150

PN 40. From DN 15 to DN 150

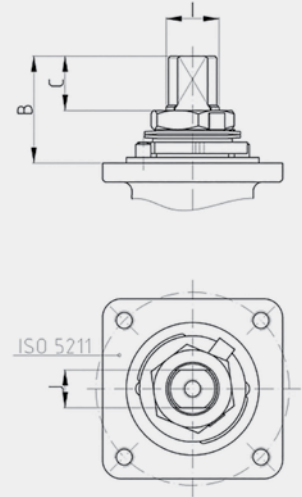
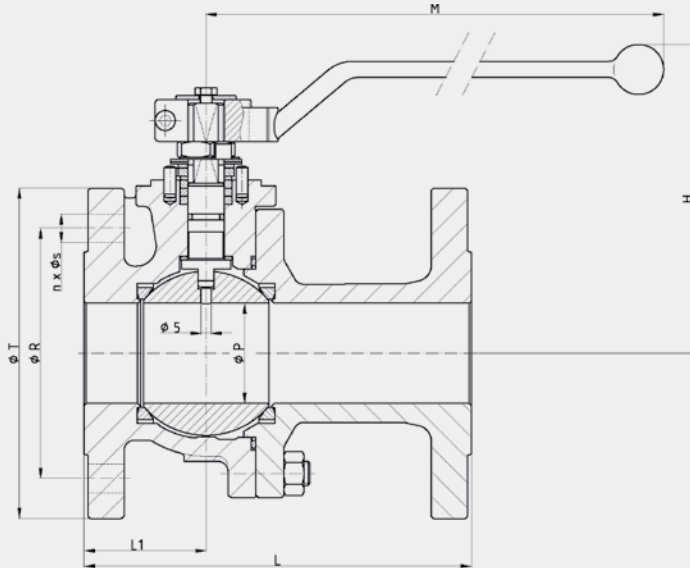

(*) Dimensions of diameters of drills ISO 5211 refer to table from page 60.

Pressure - Temperature

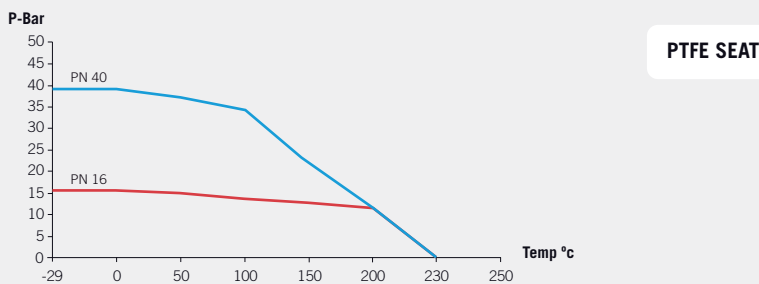

Fig. 316 (PN 16)

DN	ØP	L	L1	ØR	n x ØS	ØT	H	M	ISO 5211	B	C	I	J	WEIGHT	TORQUE	Kv
65	65	290	76	145	4x18	185	169	348	F07	44	19,7	M22x1.5	16	18,3	66	550
80	80	310	82	160	8x18	200	207	445	F10	44,5	19,7	M25x1.5	18	24	91	1000
100	100	350	90	180	8x18	220	231	495	F10	56,5	29,2	M28x1.5	20	36	130	1650
125	125	400	120	188	8x18	250	262	698	F12	56	27,6	M35x2	25	58	231	3000
150	150	480	135	212	8x22	285	298	698	F12	68	38,5	M40x2	29	81	309	4200

Fig. 340 (PN 40)

DN	ØP	L	L1	ØR	n x ØS	ØT	H	M	ISO 5211	B	C	I	J	WEIGHT	TORQUE	Kv
15	15	130	53	65	4x14	95	110	164	F05	11,2	5,7	M12x1.5	9	3	11	20
20 ⁽¹⁾	20	150	52	75	4x14	104	129	164	F05	15	9,2	M12x1.5	9	3,8	13	40
25	25	160	49	85	4x14	115	129	164	F05	22,7	10,2	M12x1.5	9	5,2	18	75
32 ⁽¹⁾	32	180	54	100	4x18	140	131	210	F05	32	13,7	M16x1.5	12	7,6	23	130
40	40	200	55	110	4x18	150	148	213	F07	41,5	19,2	M18x1.5	13	9,6	29	170
50	50	230	61	125	4x18	165	155	213	F07	41,5	19,2	M18x1.5	13	12,9	44	270
65	65	290	76	145	8x18	185	169	213	F07	44	19,7	M22x1.5	16	18,5	65	550
80	80	310	75	160	8x18	200	207	348	F10	44,5	19,7	M25x1.5	18	25	120	1000
100	100	350	91	190	8x22	235	231	445	F10	56,5	29,2	M28x1.5	20	39	178	1650
125	125	400	120	220	8x26	262	262	698	F12	56	27,6	M35x2	25	63	277	3000
150	150	480	135	250	8x26	300	298	698	F12	68	38,5	M40x2	29	87	464	4200

(*) Dimensions in mm, weight in kg and Torque in Nm.
 (***) Weights and dimensions can be changed without notice.
 (1) Under request, please consult the minimum manufacturing quantities.

EN-DIN 512

PN 16

Full Bore

PN 16. From DN 15 to DN 200

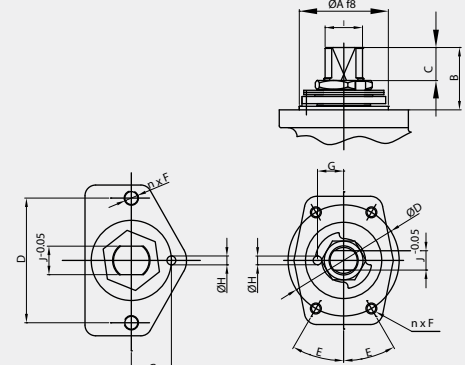
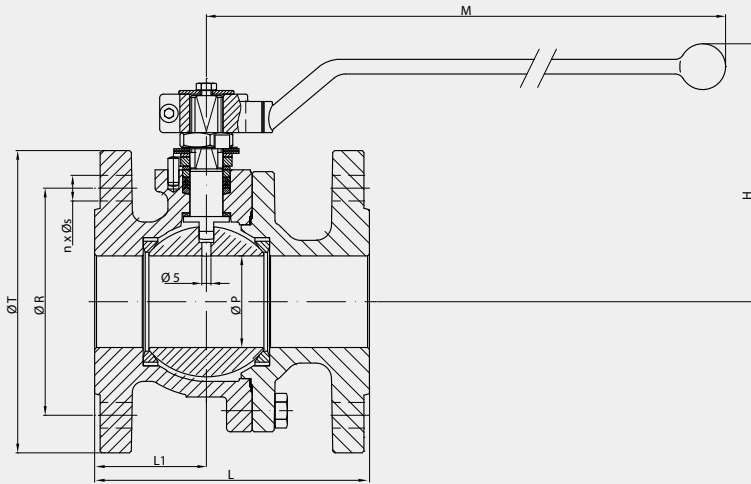

ONLY DN 15, DN 20 & DN 25

Pressure - Temperature

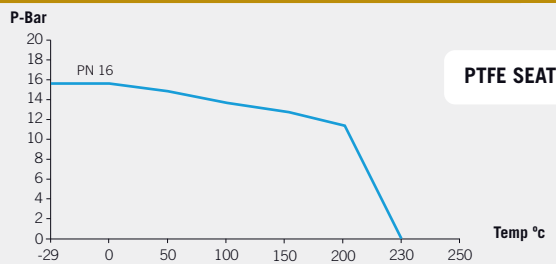

Fig. 512 (PN 16)

DN	ØP	L	L1	ØR	N x ØS	ØT	H	M	WEIGHT	TORQUE	Kv
15	15	115	50	65	4x14	95	99	164	2,39	8	20
20	20	120	52	75	4x14	105	102	164	3,19	10	40
25	25	125	52	85	4x14	115	106	164	3,9	15	75
32	32	130	54	100	4x18	140	117	210	6,3	22	130
40	40	140	55	110	4x18	150	133	213	8	25	170
50	50	150	61	125	4x18	165	141	213	10,7	40	270
65	65	170	75	145	4x18	185	152	348	15,4	55	550
80	80	180	78,5	160	8x18	200	189	445	20,2	85	1000
100	100	190	90	180	8x18	220	220	495	25,8	130	1650
125	125	325	141	210	8x18	250	254	698	49,5	180	3000
150	150	350	160	240	8x22	285	281	698	74,1	250	4200
200	200	400	200	295	12x22	340	338	868	110,5	580	9000

ACTUATOR CONNECTION

DN	ØA	B	C	D	E	N x F	G	ØH	I	J
15	29	20	8,5	40	-	2xM6	13,3	5	M12x1.5	9
20	29	20	8,5	40	-	2xM6	13,3	5	M12x1.5	9
25	29	20	8,5	40	-	2xM6	13,3	5	M12x1.5	9
32	34	30	13	Ø50	30°	4xM6	15	5	M16x1.5	12
40	39	40,5	20	Ø56	30°	4xM10	18	6	M18x1.5	13
50	39	40,5	20	Ø56	30°	4xM10	18	6	M18x1.5	13
65	47	41	18,5	Ø65	30°	4xM10	22	6	M22x1.5	16
80	55	41,5	18,5	Ø74	30°	4xM10	24	8	M25x1.5	18
100	59	53,5	28,2	Ø82	30°	4xM10	26	8	M28x1.5	20
125	68	53	27,5	Ø100	40°	4xM12	30	8	M35x2	25
150	74	65	38,5	Ø104	40°	4xM12	33	8	M40x2	29
200	94	66	37	Ø130	40°	4xM16	42	10	M45x2	32

(*) Dimensions in mm and weight in kg.
 (**) Weights and dimensions can be changed without notice.



The quality option



| BALL VALVES |

FLOATING 3 WAY BALL VALVES

1" - 8" | Class 150

DN 25 - DN 200 | PN 16

The JC Three way ball valves, have been designed to divert the flow at 90° in several options between two pipes. Three way ball valves are available with either "L" and double "L" (X) port, or T-port design. The full port design is easily automated and is available with various seat materials.



PORT COMBINATIONS

3 WAY L PORT

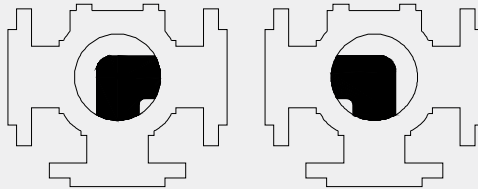

3 WAY T PORT

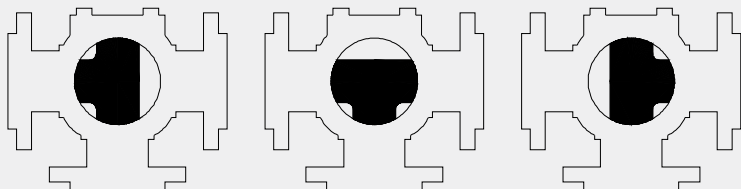

3 WAY INVERTED PORT

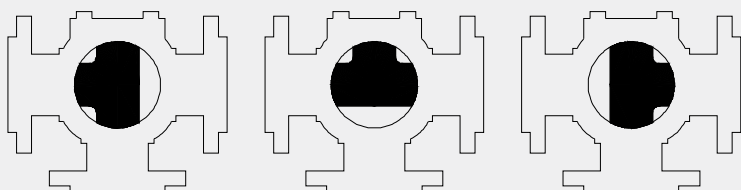

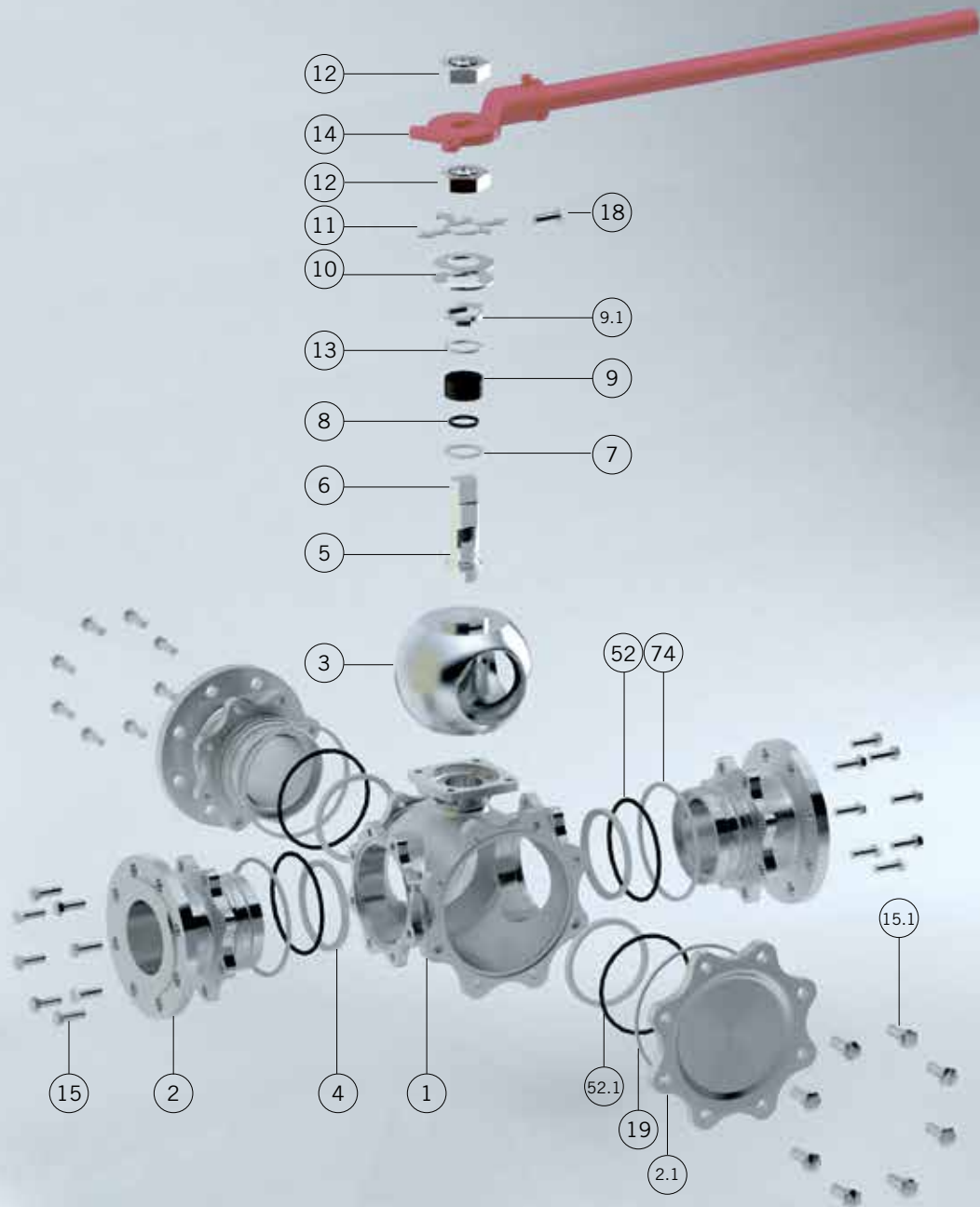

Materials

EN-DIN

ASME

916 AIT

916 IIT

915 AIT

915 IIT

Item	Description	Material		Material	
1	Body	1.0619	1.4408	A216 Gr. WCB (C _s ≤0,25%)	A351 Gr. CF8M
2	Body connector	1.0619	1.4408	A216 Gr. WCB (C _s ≤0,25%)	A351 Gr. CF8M
2.1	Side Cover	1.0619	1.4408	A216 Gr. WCB (C _s ≤0,25%)	A351 Gr. CF8M
3	Ball	A 351 Gr. CF8M		A 351 Gr. CF8M	
4	Seat ring	PTFE		PTFE	
5	Stem	A 479 Type 316		A 479 Type 316	
6	Stem thrust seal	25%GF PTFE		25%GF PTFE	
7	O'ring	FKM		FKM	
8	Stem packing	Graphite		Graphite	
9	Gland	AISI 303	AISI 316	AISI 303	AISI 316
9.1	Stop plate	F114	AISI 304	F114	AISI 304
10	Disk spring	E.N.P Carbon steel		E.N.P Carbon steel	
11	Look. Wash. Pointer	Rilsan coated Carbon St.		Rilsan coated Carbon St.	
12	Gland nut	Zinc plated carbon steel	AISI 303	Zinc plated carbon steel	AISI 303
13	Antifricion washer	25%GF. PTFE		25%GF. PTFE	
14	Wrench	Nodular iron		Nodular iron	
15	Bolt	DIN 933 A4 - 70		DIN 933 A4 - 70	
15.1	Bolt	DIN 933 A4 - 70		DIN 933 A4 - 70	
18	Stop bolt	A4-70		A4-70	
19	Body cover seal	PTFE		PTFE	
52	O'ring	FKM		FKM	
52.1	O'ring	FKM		FKM	
74	Body connector seal	PTFE		PTFE	
89	Identification plate	Stainless St.		Stainless St.	

ASME 915

Class 150

Full Bore

Class 150. From 1" to 8"

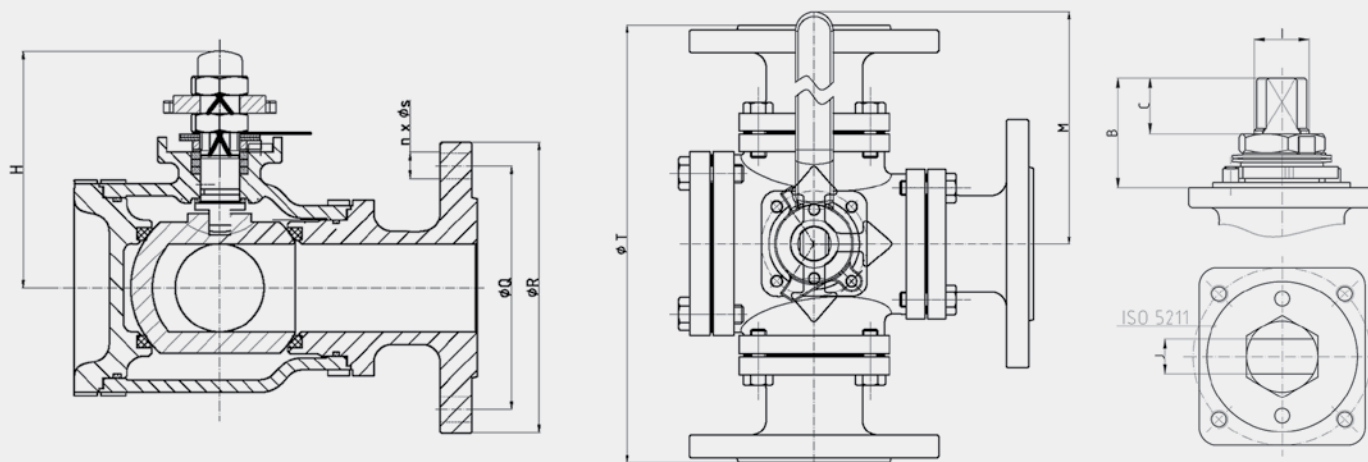

Pressure - Temperature

(*) Dimensions of diameters of drills ISO 5211 refer to table from page 60.

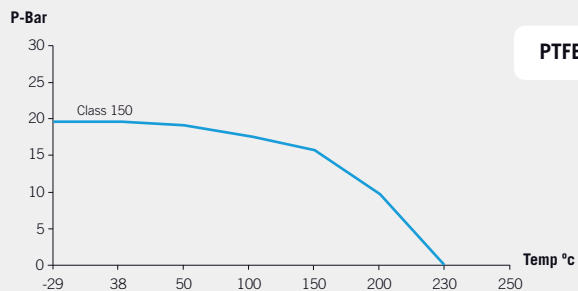
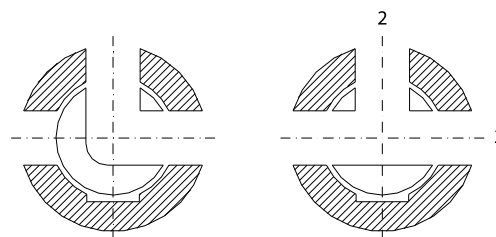

Fig. 915 (Class 150)

DN	φP	φL	A	A1	φR	n x φS	φT	H	M	ISO 5211	B	C	I	J	WEIGHT
1"	25	212	106	70	79,4	4x15,9	110	96	170	F05	22	12,2	M12x1,5	8	8
1½"	40	262	131	80	98,4	4x15,9	125	121	200	F07	33	19,2	M18x1,5	12	17
2"	50	290	145	90	120,7	4x19	150	134	350	F07	34	20,2	M22x1,5	15	25
2½"	65	325	162,5	107	139,7	4x19	180	180	350	F10	34	19,2	M22x1,5	15	34
3"	80	370	185	117	152,4	4x19	190	189	465	F10	45	27,7	M28x1,5	19	51
4"	100	430	215	148	190,5	8x19	230	230	475	F12	56	32,2	M36x1,5	24	77
6"	150	500	250	194	241,3	8x22,2	280	280	855	F14	69	41	M48x3	32	138
8"	200	600	300	270	298,5	8x22,2	345	325	855	F14	69	34	M48x3	32	

VALVE SIZE	TORQUE	
	AT MAXIMUM DIFFERENTIAL PRESSURE	
	L	T
25 (1")	32	26
40 (1 ½")	65	55
50 (2")	88	72
65 (2 ½")	140	132
80 (3")	220	205
100 (4")	440	440
150 (6")	680	680
200 (8")	1100	1100

VALVE SIZE	Kv		
	PORT L	PORT T	
		PORT 2	PORT 3
25 (1")	20,4	28,9	51
40 (1 ½")	51,85	51,85	149,6
50 (2")	42,5	80,75	249,9
65 (2 ½")	136,85	136,85	478,55
80 (3")	206,55	291,55	732,7
100 (4")	323	323	1217,2
150 (6")	726,75	726,75	3087,2
200 (8")	920	920	4810



(*) Dimensions in mm and weight in kg.
 (**) Weights and dimensions can be changed without notice.
 Torque Values in Nm.
 Kv Values in m3/h.

EN-DIN 916

PN 16

Full Bore

PN 16. From DN 25 to DN 200

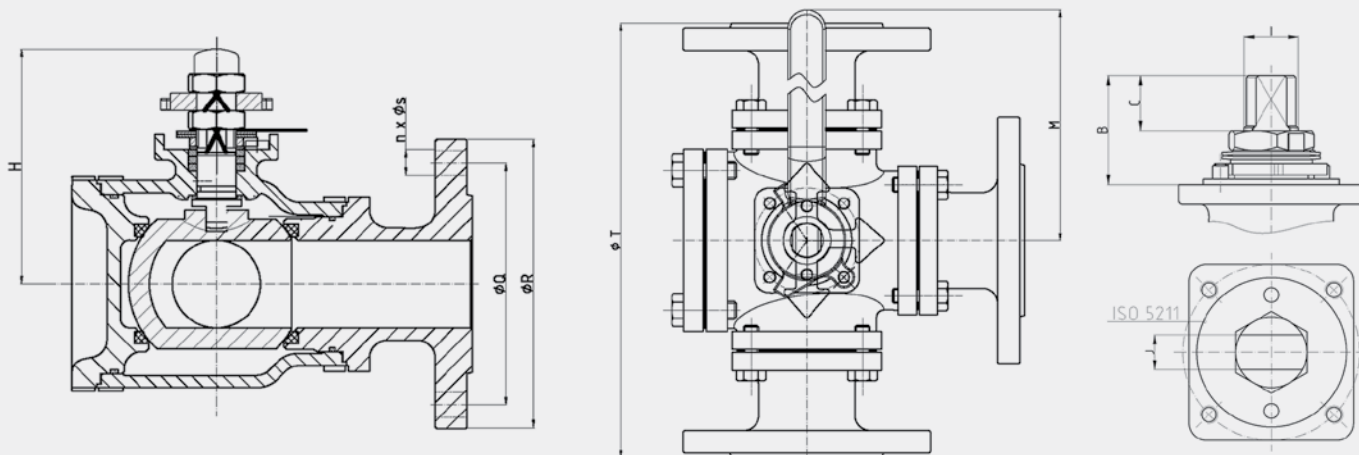

(*) Dimensions of diameters of drills ISO 5211 refer to table from page 60.

Pressure - Temperature

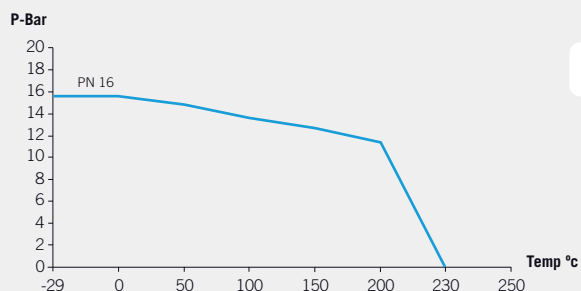

Fig. 916 (PN 16)

DN	øP	øL	A	A1	øR	n x øS	øT	H	M	ISO 5211	B	C	I	J	WEIGHT
25	25	212	106	70	85	4x14	115	96	170	F05	22	12,2	M12x1,5	8	8
40	40	262	131	80	110	4x18	150	121	200	F07	33	19,2	M18x1,5	12	17
50	50	290	145	90	125	4x18	165	134	350	F07	34	20,2	M22x1,5	15	25
65	65	325	162,5	107	145	8x18	185	180	350	F10	34	19,2	M22x1,5	15	34
80	80	370	185	117	160	8x18	200	189	465	F10	45	27,7	M28x1,5	19	51
100	100	430	215	148	180	8x18	220	230	475	F12	56	32,2	M36x1,5	24	77
150	150	500	250	194	240	8x22	285	280	855	F14	69	41	M48x3	32	138
200	200	600	300	270	295	12x22	340	325	855	F14	69	34	M48x3	32	

TORQUE

VALVE SIZE	AT MAXIMUM DIFFERENTIAL PRESSURE	
	L	T
25 (1")	35	30
40 (1 ½")	59	59
50 (2")	88	72
65 (2 ½")	140	140
80 (3")	220	220
100 (4")	360	360
150 (6")	680	680
200 (8")	850	850

Kv

VALVE SIZE	PORT L	PORT T	
		PORT 2	PORT 3
25 (1")	20,4	28,9	51
40 (1 ½")	51,85	51,85	149,6
50 (2")	42,5	80,75	249,9
65 (2 ½")	136,85	136,85	478,55
80 (3")	206,55	291,55	732,7
100 (4")	323	323	1217,2
150 (6")	726,75	726,75	3087,2
200 (8")	920	920	4810

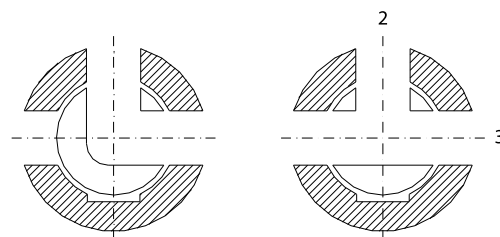

(*) Dimensions in mm and weight in kg.
 (***) Weights and dimensions can be changed without notice.
 Torque Values in Nm.
 Kv Values in m³/h.

| BALL VALVES |

SPECIAL CONSTRUCTIONS

JC Ball Valves can be delivered in special constructions as following:

STEAM JACKET

When viscous materials are handled, JC steam jacketed ball valves are recommended to prevent valve to be blocked in closed position.

The maximum steam jacket pressure is 10 Bar (1.0 Mpa) and maximum temperature is 260°.



CAVITY FILLER

Some of the roughest process controls problems involve fluids than can polymerize in place. That means they can polymerize inside body cavities and could block the valve. Cavity-filler seats are available in PTFE, Stansit, TFM.

Applications: Styrene, Butadiene, Monomers, Pharmaceuticals, Food process, ...



DOUBLE PACKING

Today's concern for the containment of fugitive emissions has brought forth in the industry a wide range of stem sealing concepts and designs aimed to eliminating stem leakage. For these applications where it is imperative that fluid containment has to be assured, double packing can be adapted to any JC ball valve.



CRYOGENIC SERVICE

JC ball valves have been widely used in low temperature and cryogenic applications, including some gas treatment processes (LNG, Methane, LPG...), requiring valves able to be operated and to assure helium leakage rates within specified limits at low temperatures. In these cases JC offers valves designed with special seats, bonnets and materials for low temperature or cryogenic service.



FULLY AUTOMATED BALL VALVES

JC Valves can be delivered with pneumatic, electric, hydraulic or gas-over-oil actuators as per customer requirements.

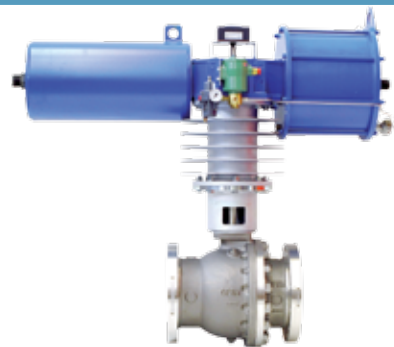

SPECIAL TAILOR MADE VALVES MADE FROM BAR OR FORGINGS

JC tailor made valves are indicated for specific demands, special circumstances, extra-ordinary applications, hard to obtain products and short delivery times. Valves are produced from bar stock materials or forgings with really short time, with exotic materials Nickel alloys (Hastelloy®, Incoloy®, Inconel®, Monel®, Alloy 20, etc.), Titanium, Duplex and Super Duplex and corrosion resistant alloys.



FULLY WELDED VALVES

The JC fully Welded Ball Valve gives it maximum strength at minimum weight as well as maximum resistance both to pipeline pressures and stresses. The compact, spherical design also eliminates body flanges, thus reducing overall size and leak paths.

JC welded body ball valves are used mainly in Gas transmission and distribution pipeline (Mid-stream), typical for underground and buried installation.



P-T CHARTS FOR SEAT MATERIALS

PTFE (Class 600)

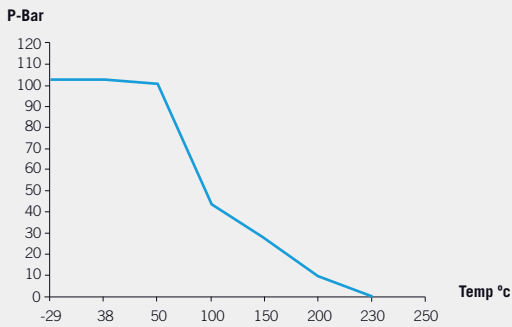

RPTFE (Class 1500)

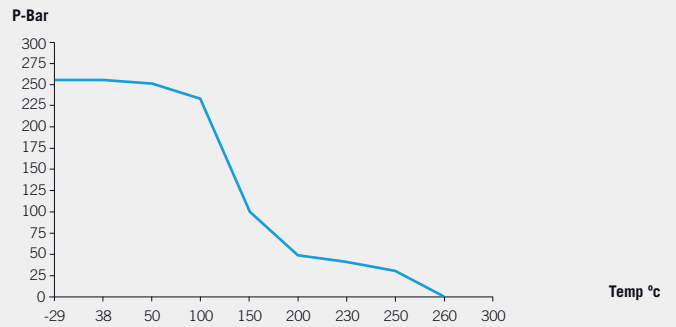

DEVLON V (Class 1500)

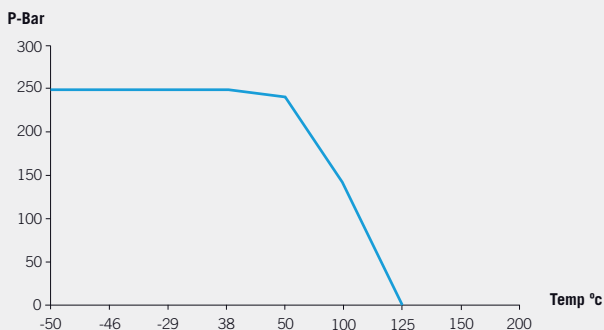

PEEK (Class 2500)

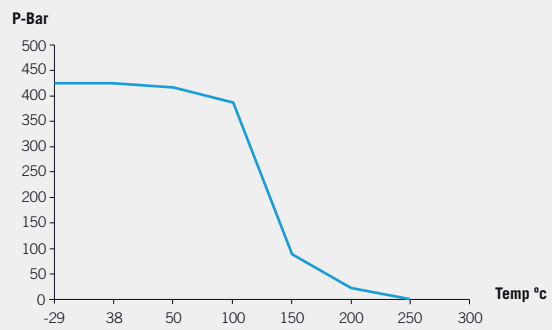

DIMENSIONS OF DRILLS ACCORDING TO ISO 5211

FLANGE TYPE	DIAMETER OF BOLTS CIRCLE	NUMBER SCREWS	DIAMETER OF DRILLS
F03	36	4	M5
F04	42	4	M5
F05	50	4	M6
F07	70	4	M8
F10	102	4	M10
F12	125	4	M12
F14	140	4	M16
F16	165	4	M20
F25	254	8	M16
F30	298	8	M20
F35	356	8	M30
F40	406	8	M36
F48	483	12	M36

JC VALVES

The quality option

MORE PRODUCTS



GATE, GLOBE & CHECK VALVES - TRIPLE OFFSET BUTTERFLY VALVES - STRAINERS

ACCESSORIES



PNEUMATIC ACTUATOR - ELECTRIC ACTUATOR - HYDRAULIC ACTUATOR
GAS OVER OIL ACTUATOR - WORM GEAR - LOCKING DEVICES - STEM EXTENSIONS

BALL VALVES

JC FÁBRICA DE VÁLVULAS S.A.U.

Av. Segle XXI, 75 - Pol. Ind. Can Calderon
08830 Sant Boi del Llobregat
Barcelona (Spain)
Tel. +34 93 654 86 86
Fax +34 93 654 86 87

sales@jc-valves.com
www.jc-valves.com



Edition 04/2017

ISO